

600 V, 15 A
High Voltage 3-phase Motor Driver
SIM2-151A

Description

The SIM2-151A is a high voltage 3-phase motor driver in which transistors, pre-drive circuits, and bootstrap diodes with current-limiting resistors are highly integrated. The product can run on a 3-shunt current detection system and optimally control the inverter systems of medium-capacity motors that require universal input standards. The product uses a compact DIP40 package and supports an output current of 15 A.

Features

- Pb-free (RoHS Compliant)
- Isolation Voltage: 2000 V (for 1 min)
UL-recognized Component (File No.: E118037)
- Temperature Sensing Function
- Built-in Bootstrap Diodes with Current Limiting Resistors (250 Ω)
- CMOS-compatible Input (3.3 V or 5 V)
- Fault Signal Output at Protection Activation
- Protections Include:
 - Undervoltage Lockout for Power Supply
 - High-side (UVLO_VB): Auto-restart
 - Low-side (UVLO_VCC): Auto-restart
 - Overcurrent Protection (OCP): Auto-restart
 - Thermal Shutdown (TSD): Auto-restart, TSD operation temperature $\pm 5\text{ }^{\circ}\text{C}$

Package

DIP40 (Leadform: 2980)
 Pin Pitch: 1.778 mm
 Mold Dimensions: 35.7 mm × 14.6 mm × 4.2 mm

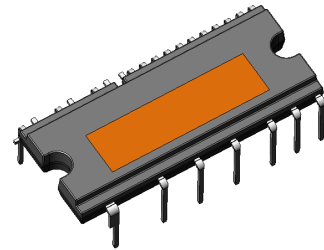

Not to scale

Specifications

- Breakdown Voltage: 600 V
- Output Current: 15 A

Applications

For motor drives such as:

- Refrigerator Compressor Motor
- Air Conditioner Compressor Motor

Typical Application

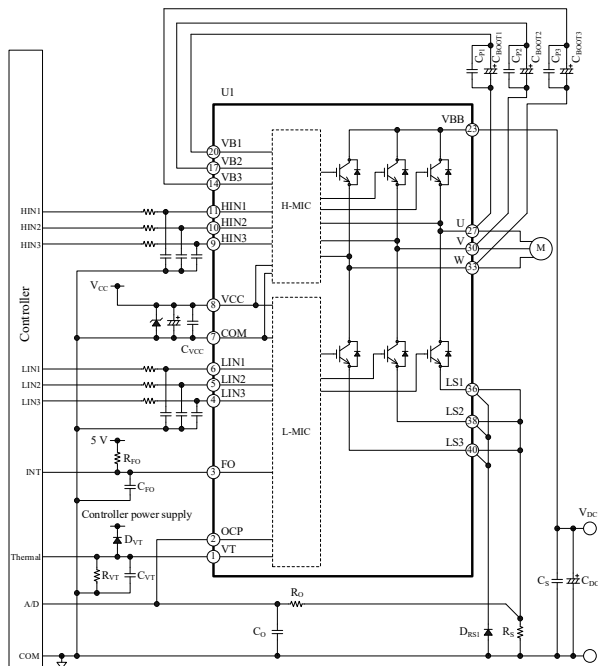

Contents

Description	1
Contents	2
1. Absolute Maximum Ratings	4
2. Recommended Operating Conditions	5
3. Electrical Characteristics	6
3.1. Characteristics of Control Parts	6
3.2. Bootstrap Diode Characteristics	7
3.3. Thermal Resistance Characteristics	7
3.4. Transistor Characteristics	8
4. Mechanical Characteristics	9
5. Insulation Distance	9
6. Truth Table	10
7. Block Diagram	11
8. Pin Configuration Definitions	12
9. Typical Applications	13
10. Physical Dimensions	15
11. Marking Diagram	17
12. Functional Descriptions	18
12.1. Turning On and Off the IC	18
12.2. Pin Descriptions	18
12.2.1. U, V, and W	18
12.2.2. VB1, VB2, and VB3	18
12.2.3. VCC	19
12.2.4. COM	19
12.2.5. HIN1, HIN2, and HIN3; LIN1, LIN2, and LIN3	20
12.2.6. VBB	20
12.2.7. LS1, LS2, and LS3	20
12.2.8. OCP	21
12.2.9. FO	21
12.2.10. VT	22
12.3. Temperature Sensing Function	22
12.4. Protection Functions	22
12.4.1. Fault Signal Output	23
12.4.2. Undervoltage Lockout for Power Supply (UVLO)	23
12.4.3. Overcurrent Protection (OCP)	24
12.4.4. Thermal Shutdown (TSD)	25
13. Design Notes	25
13.1. PCB Pattern Layout	25
13.2. Considerations in Heatsink Mounting	25
13.3. Considerations in IC Characteristics Measurement	26
14. Calculating Power Losses and Estimating Junction Temperature	27
14.1. IGBT Steady-state Loss, P_{ON}	27
14.2. IGBT Switching Loss, P_{SW}	27
14.3. Estimating Junction Temperature of IGBT	27
14.4. Freewheeling Diode Steady-state Loss, P_F	28
14.5. Estimating Junction Temperature of Freewheeling Diode	28
15. Performance Curves	29

15.1. Performance Curves of Control Parts-----	29
15.2. Performance Curves of Output Parts-----	34
15.2.1. Output Transistor Performance Curves-----	34
15.2.2. Switching Loss Curves-----	34
15.3. Allowable Effective Current Curves-----	35
15.4. Transient Thermal Resistance Curve-----	36
15.5. Short Circuit SOA (Safe Operating Area)-----	36
16. Pattern Layout Example-----	37
17. Typical Motor Driver Application-----	39
Important Notes-----	40

1. Absolute Maximum Ratings

Current polarities are defined as follows: current going into the IC (sinking) is positive current (+); current coming out of the IC (sourcing) is negative current (-).

Unless specifically noted, $T_A = 25\text{ }^\circ\text{C}$.

Parameter	Symbol	Conditions	Rating	Unit
Main Supply Voltage (DC)	V_{DC}	VBB-LSx	450	V
Main Supply Voltage (Surge)	$V_{DC(SURGE)}$	VBB-LSx	500	V
IGBT Breakdown Voltage	V_{CES}	$V_{CC} = 15\text{ V}$, $I_C = 100\text{ }\mu\text{A}$, $V_{IN} = 0\text{ V}$	600	V
Logic Supply Voltage	V_{CC}	VCC-COM	20	V
	V_{BS}	VBx-U/V/W	20	
Output Current ⁽¹⁾	I_O	$T_C = 25\text{ }^\circ\text{C}$, $T_J < 150\text{ }^\circ\text{C}$	15	A
Output Current (Pulse)	I_{OP}	$T_C = 25\text{ }^\circ\text{C}$, pulse width $\leq 100\text{ }\mu\text{s}$, duty cycle = 1%, single pulse	30	A
Input Voltage	V_{IN}	HINx-COM, LINx-COM	-0.5 to 7	V
FO Pin Voltage	V_{FO}	FO-COM	-0.5 to 7	V
OCP Pin Voltage	V_{OCP}	OCP-COM	-10 to 7	V
Operating Case Temperature ⁽²⁾	$T_{C(OP)}$		-30 to 100	$^\circ\text{C}$
Junction Temperature ⁽³⁾	T_J		150	$^\circ\text{C}$
Storage Temperature	T_{STG}		-40 to 150	$^\circ\text{C}$
Isolation Voltage ⁽⁴⁾	$V_{ISO(RMS)}$	Between surface of heatsink side and each pin; AC, 60 Hz, 1 min	2000	V

⁽¹⁾ Should be derated depending on an actual case temperature. See Section 15.3.

⁽²⁾ Refers to a case temperature measured during IC operation.

⁽³⁾ Refers to the junction temperature of each chip built in the IC, including the control MICs, transistors, and freewheeling diodes.

⁽⁴⁾ Refers to voltage conditions to be applied between all of the pins and the case. All the pins have to be shorted.

2. Recommended Operating Conditions

Parameter	Symbol	Conditions	Min.	Typ.	Max.	Unit
Main Supply Voltage	V_{DC}	VBB-COM	—	300	400	V
Logic Supply Voltage	V_{CC}	VCC-COM	13.5	—	16.5	V
	V_{BS}	VBx-U/V/W	13	—	16.5	V
Input Voltage (HINx, LINx)	V_{IN}		0	—	5.5	V
Minimum Input Pulse Width	$t_{IN(MIN)ON}$		0.5	—	—	μ s
	$t_{IN(MIN)OFF}$		0.5	—	—	μ s
Dead Time of Input Signal	t_{DEAD}		1.5	—	—	μ s
FO Pin Pull-up Resistor	R_{FO}		3.3	—	10	k Ω
FO Pin Pull-up Voltage	V_{FO}		3.0	—	5.5	V
FO Pin Noise Filter Capacitor	C_{FO}		0.001	—	0.01	μ F
VT Pin Pull-down Resistor ⁽¹⁾	R_{VT}		100	—	—	k Ω
VT Pin Pull-down Capacitor	C_{VT}		0.001	—	0.01	μ F
Bootstrap Capacitor	C_{BOOT}		10	—	220	μ F
Shunt Resistor ⁽²⁾	R_S	$I_{OP} \leq 30$ A	18	—	—	m Ω
RC Filter Resistor ⁽³⁾	R_O		—	—	100	Ω
RC Filter Capacitor	C_O		—	—	10	nF
PWM Carrier Frequency	f_C		—	—	20	kHz

⁽¹⁾ Refers to a combined resistance with the input impedance of the microcontroller.

⁽²⁾ Should be a low-inductance resistor.

⁽³⁾ Requires the time constants that satisfy the following equation (see also Section 12.4.3): $R_O \times C_O < 1.0 \mu$ s .

3. Electrical Characteristics

Current polarities are defined as follows: current going into the IC (sinking) is positive current (+); current coming out of the IC (sourcing) is negative current (-).

Unless specifically noted, $T_A = 25\text{ }^\circ\text{C}$, $V_{CC} = 15\text{ V}$.

3.1. Characteristics of Control Parts

Parameter	Symbol	Conditions	Min.	Typ.	Max.	Unit
Power Supply Operation						
Logic Operation Start Voltage	$V_{CC(ON)}$	VCC-COM	10.5	11.5	12.5	V
	$V_{BS(ON)}$	VBx-U/V/W	9.5	10.5	11.5	V
Logic Operation Stop Voltage	$V_{CC(OFF)}$	VCC-COM	10.0	11.0	12.0	V
	$V_{BS(OFF)}$	VBx-U/V/W	9.0	10.0	11.0	V
Logic Supply Current	I_{CC}		—	2.3	—	mA
	I_{BS}	VBx-U/V/W = 15 V, HINx = 5 V; VBx pin current in 1-phase operation	—	85	180	μA
Input Signal						
High Level Input Threshold Voltage (HINx, LINx)	V_{IH}		—	2.0	2.5	V
Low Level Input Threshold Voltage (HINx, LINx)	V_{IL}		1.0	1.5	—	V
High Level Input Current (HINx, LINx)	I_{IH}	$V_{IN} = 5\text{ V}$	—	250	500	μA
Low Level Input Current (HINx, LINx)	I_{IL}	$V_{IN} = 0\text{ V}$	—	—	2	μA
Fault Signal Output						
FO Pin Voltage at Fault Signal Output	V_{FOL}	$V_{FO} = 5\text{ V}$, $R_{FO} = 10\text{ k}\Omega$	0	—	0.5	V
FO Pin Voltage in Normal Operation	V_{FOH}	$V_{FO} = 5\text{ V}$, $R_{FO} = 10\text{ k}\Omega$	4.8	—	—	V
Protection						
OCP Threshold Voltage	V_{TRIP}	OCP-COM	0.475	0.50	0.525	V
OCP Blanking Time	$t_{BK(OCP)}$	$V_{OCP} = 1.0\text{ V}$	—	370	—	ns
OCP Hold Time	t_p		5	10	—	ms
Temperature Sensing Voltage ⁽¹⁾⁽²⁾	V_T	$T_{J(L-MIC)} = 125\text{ }^\circ\text{C}$	3.003	3.130	3.256	V
TSD Operating Temperature ⁽²⁾	T_{DH}	No heatsink	115	120	125	$^\circ\text{C}$
TSD Releasing Temperature ⁽²⁾	T_{DL}	No heatsink	95	100	105	$^\circ\text{C}$

⁽¹⁾ Determined by the junction temperature of the low-side control parts, but not of the output transistors.

⁽²⁾ Guaranteed by design.

3.2. Bootstrap Diode Characteristics

Parameter	Symbol	Conditions	Min.	Typ.	Max.	Unit
Bootstrap Diode Leakage Current	I_{LBD}	$V_R = 600 \text{ V}$	—	—	10	μA
Bootstrap Diode Forward Voltage ⁽¹⁾	V_{FB}	$I_{FB} = 10 \text{ mA}$	—	3.2	—	V
Bootstrap Diode Series Resistor	R_{BOOT}	$T_C = 25 \text{ }^\circ\text{C}$	—	250	—	Ω

3.3. Thermal Resistance Characteristics

Parameter	Symbol	Conditions	Min.	Typ.	Max.	Unit
Junction-to-Case Thermal Resistance ⁽²⁾	$R_{(J-C)Q}$ ⁽³⁾	1 element operating (IGBT)	—	—	3.6	$^\circ\text{C/W}$
	$R_{(J-C)F}$ ⁽⁴⁾	1 element operating (freewheeling diode)	—	—	3.8	$^\circ\text{C/W}$

⁽¹⁾ Includes a voltage drop in the current-limiting resistor.

⁽²⁾ Refers to a case temperature at the measurement point described in Figure 3-1, below.

⁽³⁾ Refers to steady-state thermal resistance between the junction of the built-in transistors and the case. For transient thermal characteristics, see Section 15.4.

⁽⁴⁾ Refers to steady-state thermal resistance between the junction of the built-in freewheeling diodes and the case.

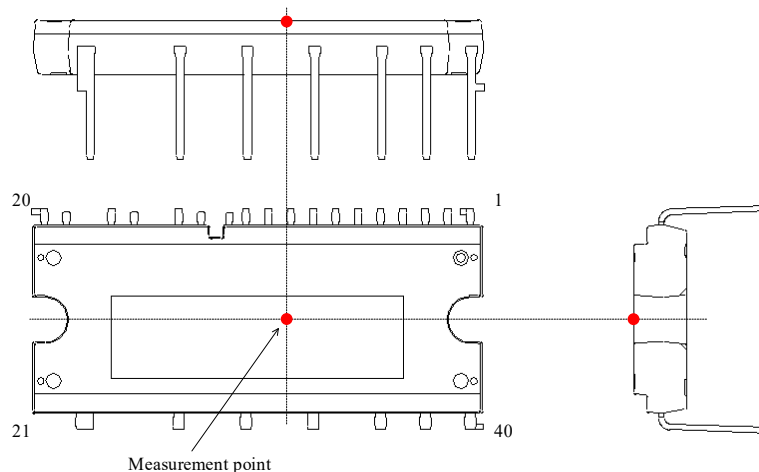

Figure 3-1. Case Temperature Measurement Point

3.4. Transistor Characteristics

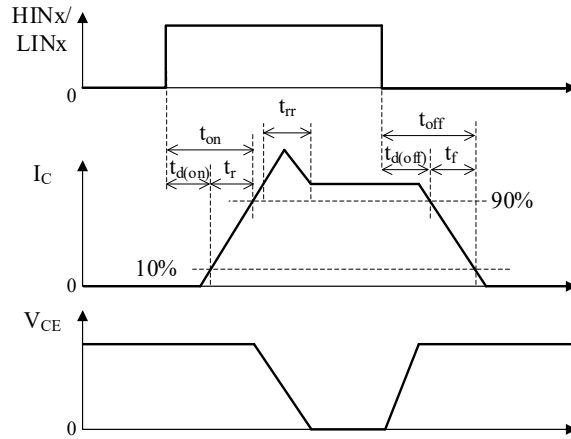

Figure 3-2. Switching Characteristics Definitions

Parameter	Symbol	Conditions	Min.	Typ.	Max.	Unit
Collector-to-Emitter Leakage Current	I_{CES}	$V_{CE} = 600\text{ V}, V_{IN} = 0\text{ V}$	—	—	1	mA
Collector-to-Emitter Saturation Voltage	$V_{CE(SAT)}$	$I_C = 10\text{ A}, V_{IN} = 5\text{ V}$	—	1.6	2.0	V
Diode Forward Voltage	V_F	$I_F = 10\text{ A}, V_{IN} = 0\text{ V}$	—	1.75	2.15	V
High-side Switching						
Diode Reverse Recovery Time	t_{rr}	$V_{DC} = 300\text{ V},$ $I_C = 15\text{ A},$ $V_{IN} = 0 \rightarrow 5\text{ V}$ or $5 \rightarrow 0\text{ V},$ $T_J = 25\text{ }^\circ\text{C},$ inductive load	—	145	—	ns
Turn-on Delay Time	$t_{d(on)}$		—	370	—	ns
Rise Time	t_r		—	60	—	ns
Turn-off Delay Time	$t_{d(off)}$		—	610	—	ns
Fall Time	t_f		—	155	—	ns
Low-side Switching						
Diode Reverse Recovery Time	t_{rr}	$V_{DC} = 300\text{ V},$ $I_C = 15\text{ A},$ $V_{IN} = 0 \rightarrow 5\text{ V}$ or $5 \rightarrow 0\text{ V},$ $T_J = 25\text{ }^\circ\text{C},$ inductive load	—	150	—	ns
Turn-on Delay Time	$t_{d(on)}$		—	370	—	ns
Rise Time	t_r		—	65	—	ns
Turn-off Delay Time	$t_{d(off)}$		—	610	—	ns
Fall Time	t_f		—	155	—	ns

4. Mechanical Characteristics

Parameter	Conditions	Min.	Typ.	Max.	Unit
Heatsink Mounting Screw Torque	*	0.588	—	0.784	N·m
Flatness of Heatsink Attachment Area	See Figure 4-1.	0	—	100	μm
Package Weight		—	6	—	g

* Requires using a metric screw of M3 and a plain washer of 7 mm (φ). For more on screw tightening, see Section 13.2.

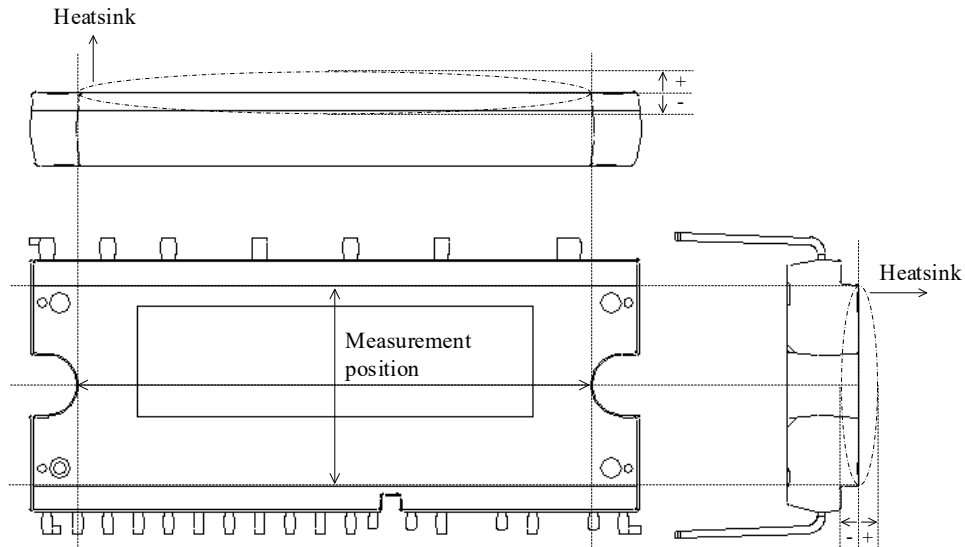

Figure 4-1. Flatness Measurement Position

5. Insulation Distance

Parameter	Conditions	Min.	Typ.	Max.	Unit
Clearance	Between heatsink* and leads.	—	1.98	—	mm
Creepage	See Figure 5-1.	3.2	—	—	mm

* Refers to when a heatsink to be mounted is flat. If your application requires a clearance exceeding the maximum distance given above, use an alternative (e.g., a convex heatsink) that will meet the target requirement.

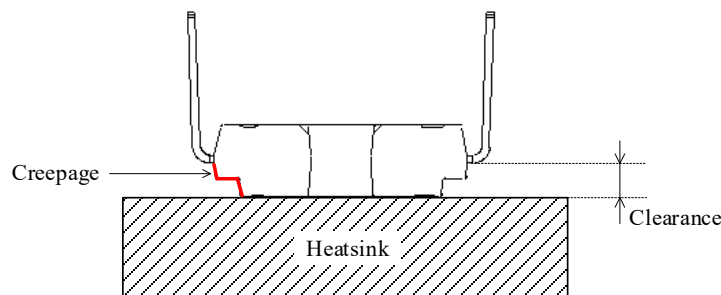

Figure 5-1. Insulation Distance Definitions

6. Truth Table

Table 6-1 is a truth table that provides the logic level definitions of operation modes.

In the case where HINx and LINx pin signals in each phase are high at the same time, both the high- and low-side IGBTs become on (simultaneous on-state). Therefore, the input signals for the HINx and LINx pins, require dead time setting so that such a simultaneous on-state event can be avoided.

After the IC recovers from a UVLO_VCC condition, the high- and low-side transistors resume switching, according to the input logic levels of the HINx and LINx signals (level-triggered).

After the IC recovers from a UVLO_VB condition, the high-side transistors resume switching at the next rising edge of an HINx signal (edge-triggered).

Table 6-1. Truth Table for Operation Modes

Mode	HINx	LINx	High-side Transistor	Low-side Transistor
Normal Operation	L	L	OFF	OFF
	H	L	ON	OFF
	L	H	OFF	ON
	H	H	ON	ON
Undervoltage Lockout for High-side Power Supply (UVLO_VB)	L	L	OFF	OFF
	H	L	OFF	OFF
	L	H	OFF	ON
	H	H	OFF	ON
Undervoltage Lockout for Low-side Power Supply (UVLO_VCC)	L	L	OFF	OFF
	H	L	OFF	OFF
	L	H	OFF	OFF
	H	H	OFF	OFF
Overcurrent Protection (OCP)	L	L	OFF	OFF
	H	L	ON	OFF
	L	H	OFF	OFF
	H	H	ON	OFF
Thermal Shutdown (TSD)	L	L	OFF	OFF
	H	L	ON	OFF
	L	H	OFF	OFF
	H	H	ON	OFF

7. Block Diagram

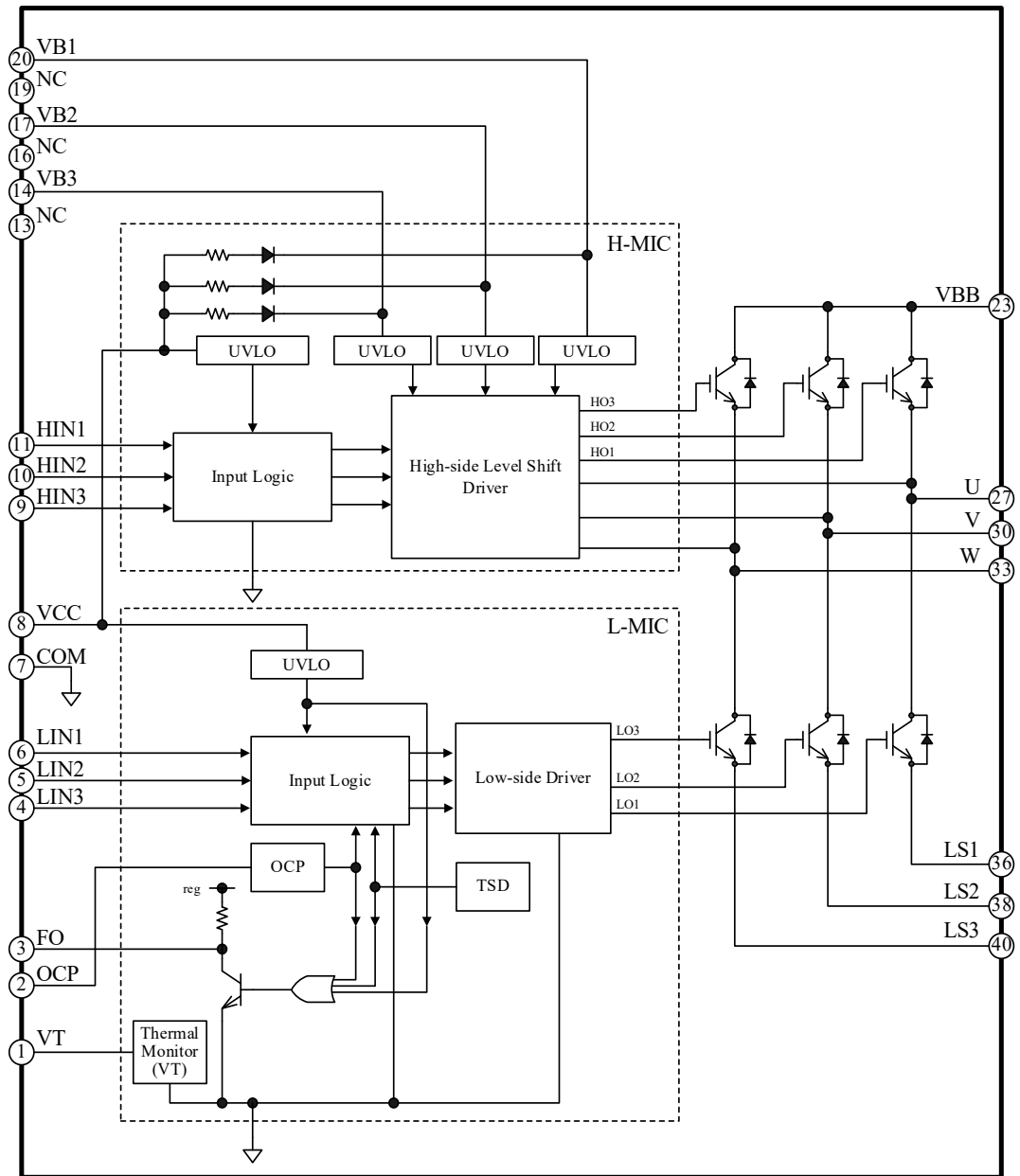

8. Pin Configuration Definitions

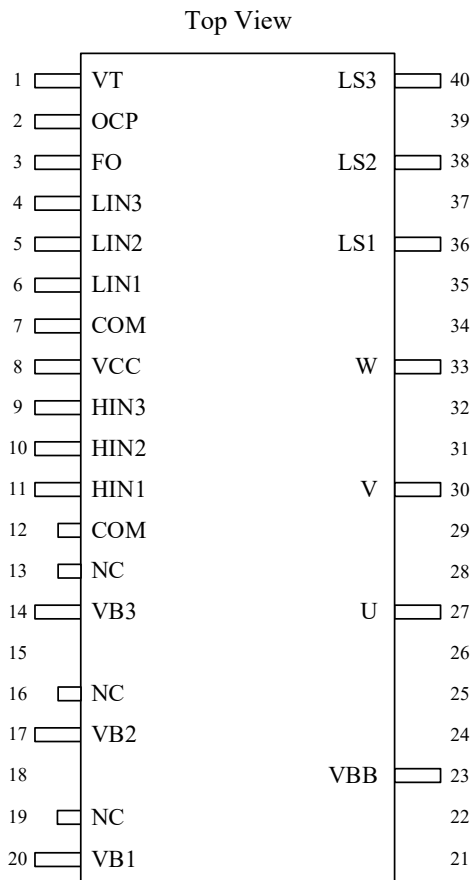

Pin Number	Pin Name	Description
1	VT	Temperature sensing voltage output
2	OCP	Input for overcurrent protection
3	FO1	Fault signal output
4	LIN3	Logic input for W-phase low-side gate driver
5	LIN2	Logic input for V-phase low-side gate driver
6	LIN1	Logic input for U-phase low-side gate driver
7	COM	Logic ground
8	VCC	Logic supply voltage input
9	HIN3	Logic input for W-phase high-side gate driver
10	HIN2	Logic input for V-phase high-side gate driver
11	HIN1	Logic input for U-phase high-side gate driver
12	COM	(Pin trimmed) logic ground
13	NC	(Pin trimmed) no connection
14	VB3	W-phase high-side floating supply voltage input
15	—	Pin removed
16	NC	(Pin trimmed) no connection
17	VB2	V-phase high-side floating supply voltage input
18	—	Pin removed
19	NC	(Pin trimmed) no connection
20	VB1	U-phase high-side floating supply voltage input
21	—	Pin removed
22	—	Pin removed
23	VBB	Positive DC bus supply voltage
24	—	Pin removed
25	—	Pin removed
26	—	Pin removed
27	U	U-phase output / U-phase high-side floating supply ground
28	—	Pin removed
29	—	Pin removed
30	V	V-phase output / V-phase high-side floating supply ground
31	—	Pin removed
32	—	Pin removed
33	W	W-phase output / W-phase high-side floating supply ground
34	—	Pin removed
35	—	Pin removed
36	LS1	U-phase IGBT emitter
37	—	Pin removed
38	LS2	V-phase IGBT emitter
39	—	Pin removed
40	LS3	W-phase IGBT emitter

9. Typical Applications

CR filters and Zener diodes should be added to your application as needed. This is to protect each pin against surge voltages causing malfunctions, and to avoid the IC being used under the conditions exceeding the absolute maximum ratings where critical damage is inevitable. Then, check all the pins thoroughly under actual operating conditions to ensure that your application works flawlessly.

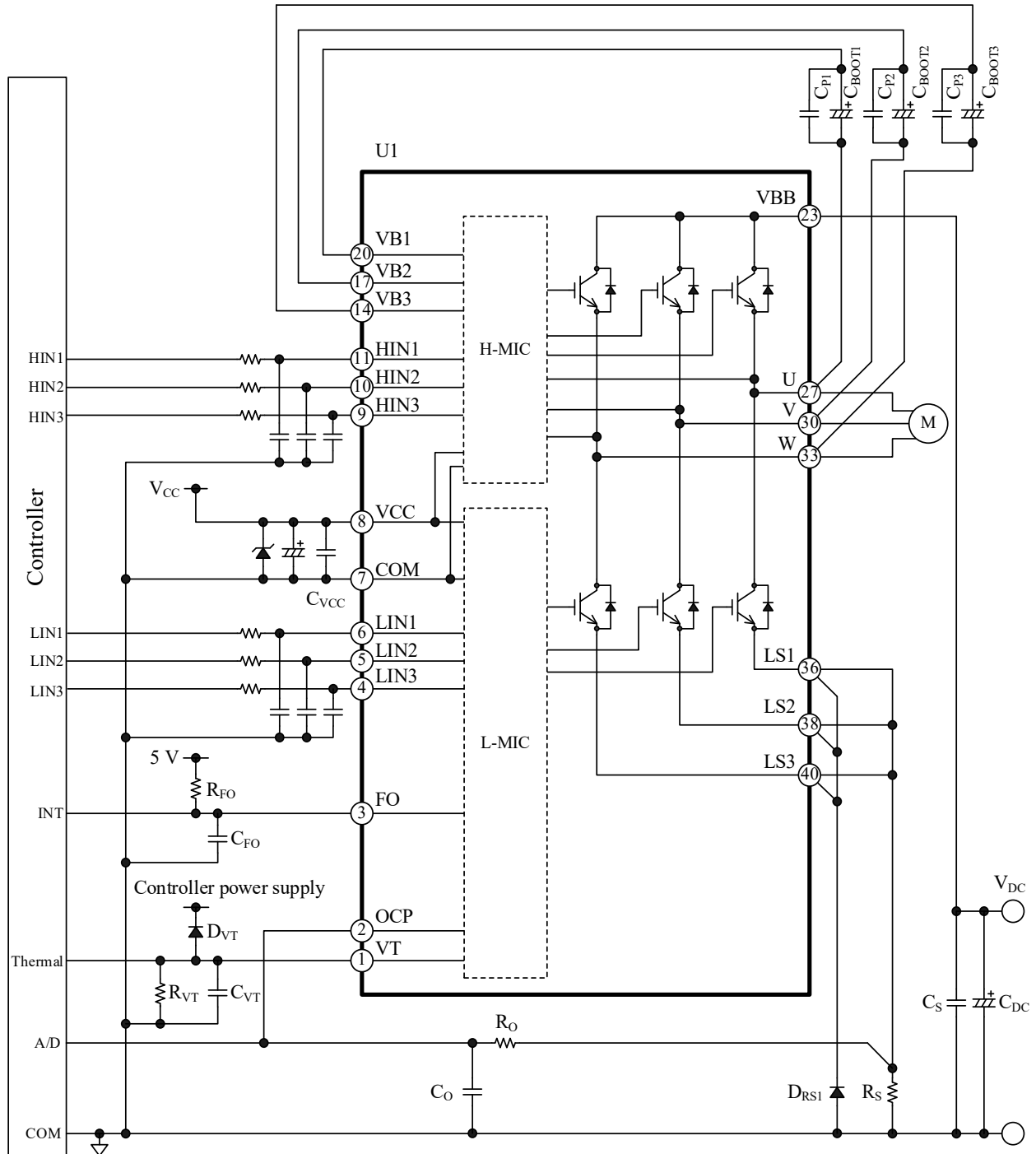

Figure 9-1. Typical Application Using a Single Shunt Resistor

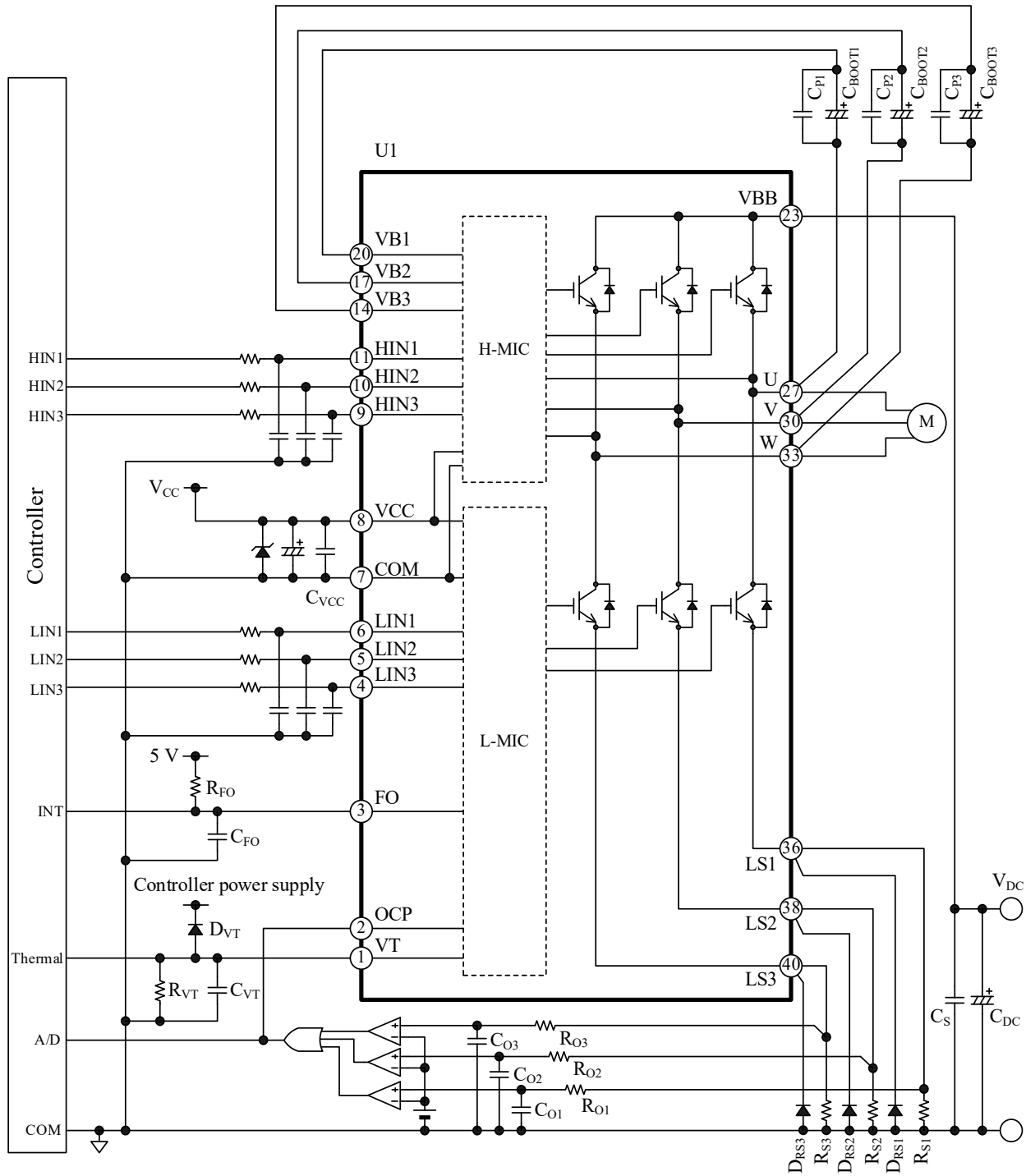
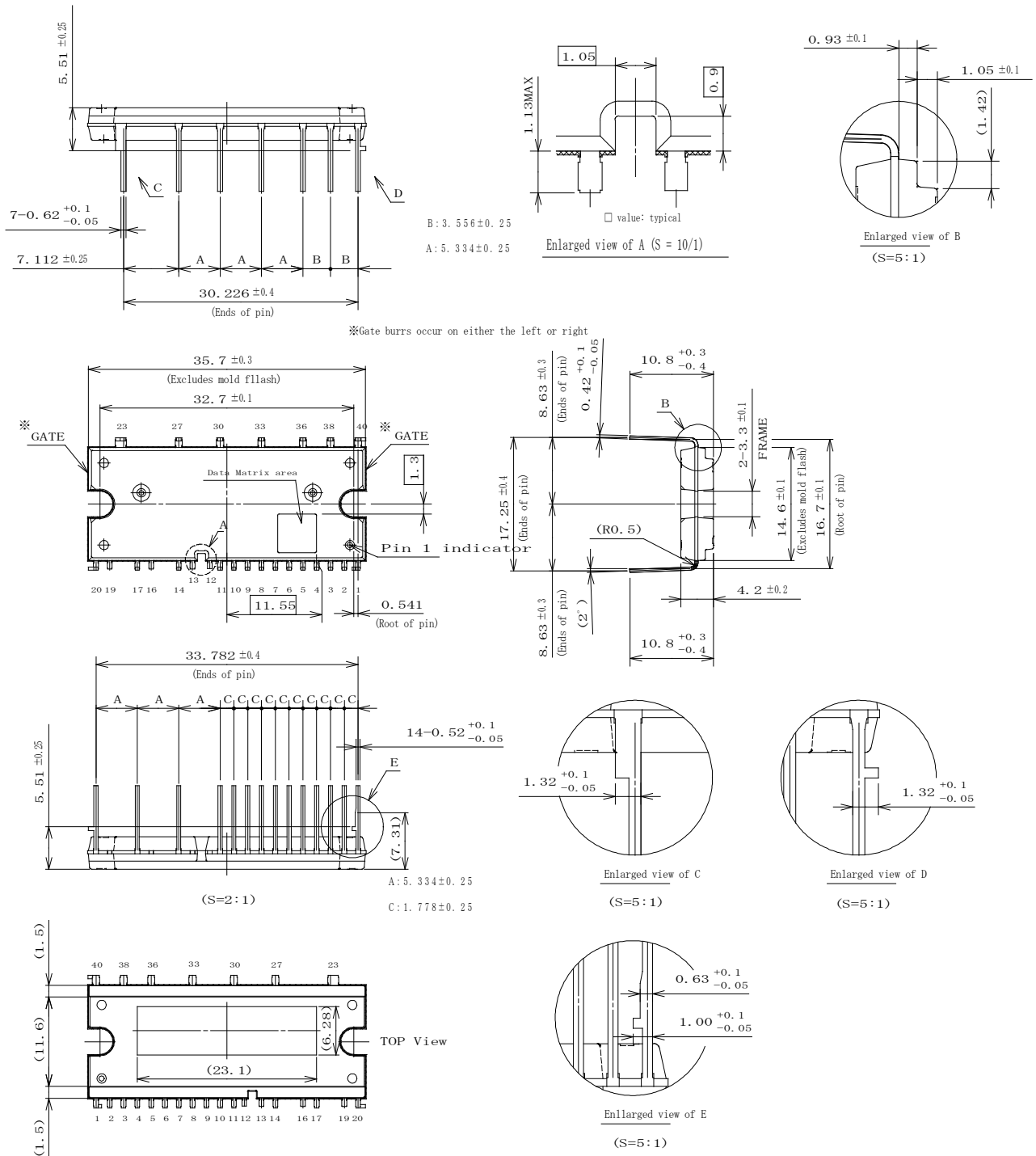

Figure 9-2. Typical Application Using Three Shunt Resistors

10. Physical Dimensions

- DIP40
(Leadform: 2980)



NOTES:

- Dimensions in millimeters
- Dimensions exclude gate burrs. The actual gate may be generated on either the right or left side as illustrated.
- Pb-free (RoHS compliant)
- Ejector pin marks left on the branding side include “○” and “◎”.

SIM2-151A

• Land Pattern Example

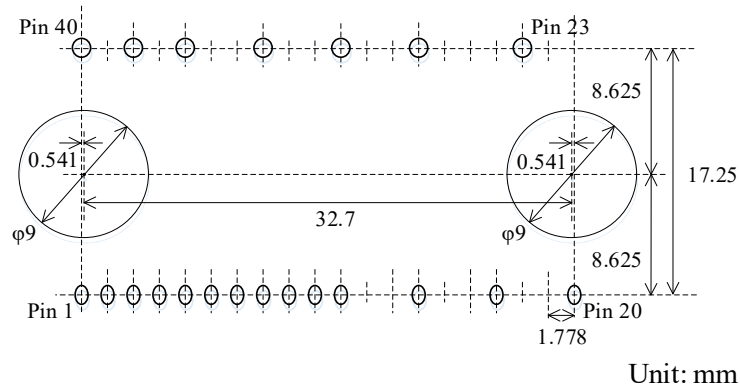

• Reference PCB Hole Sizes

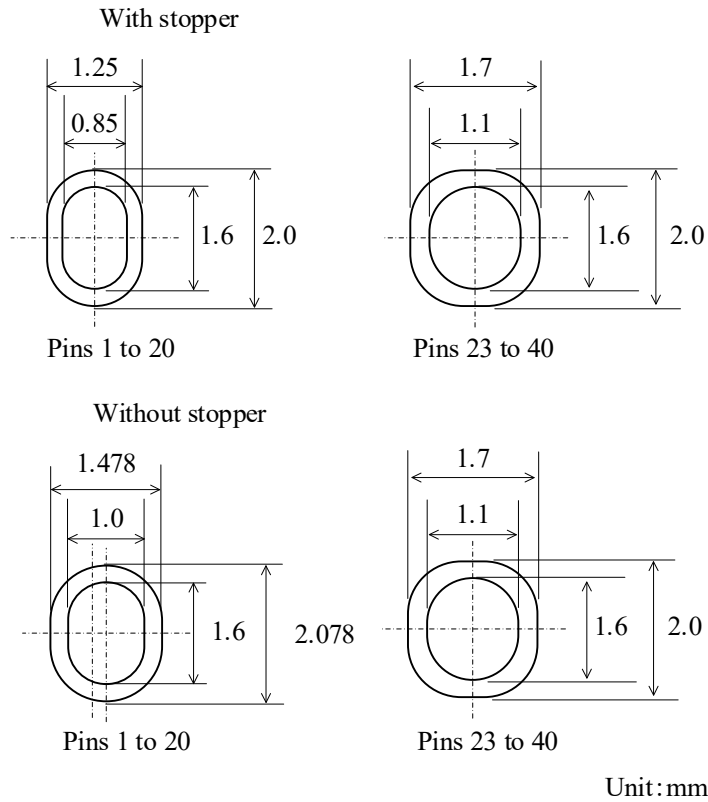

SIM2-151A

11. Marking Diagram

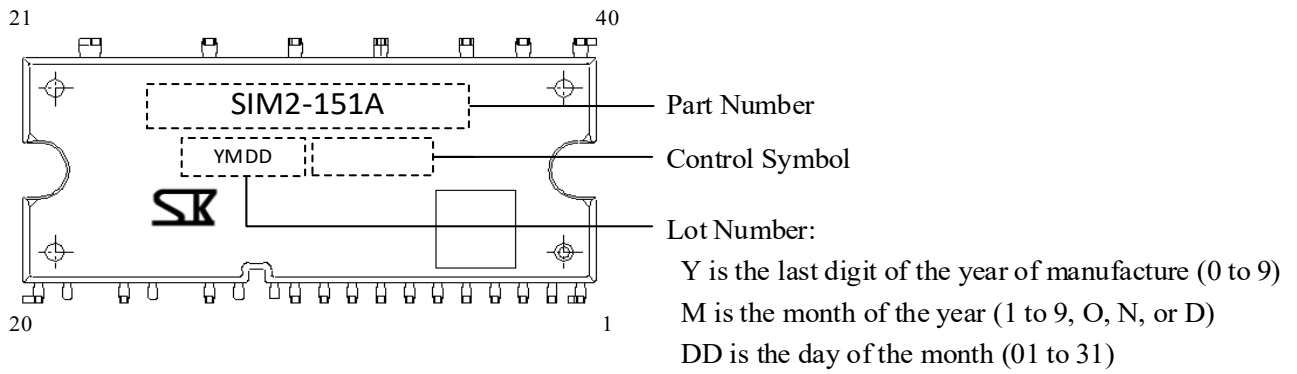
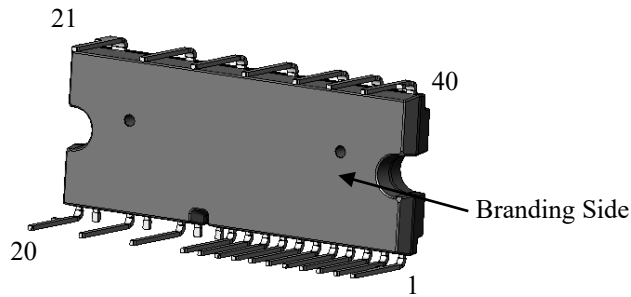

12. Functional Descriptions

All the characteristic values given in this section are typical values, unless they are specified as minimum or maximum.

For pin descriptions, this section employs a notation system that denotes a pin name with the arbitrary letter “x”, depending on context. The U-, V-, and W-phases are represented as the pin numbers 1, 2, and 3, respectively. Thus, “the VBx pin” is used when referring to any or all of the VB1, VB2, and VB3 pins.

12.1. Turning On and Off the IC

The procedures listed below provide recommended startup and shutdown sequences. To turn on the IC properly, do not apply any voltage on the VBB, HINx, and LINx pins until the VCC pin voltage has reached a stable state ($V_{CC(ON)} \geq 12.5$ V). It is required to fully charge bootstrap capacitors, C_{BOOTx} , at startup (see Section 12.2.2).

To turn off the IC, set the HINx and LINx pins to logic low (or “L”), and then decrease the VCC pin voltage.

12.2. Pin Descriptions

12.2.1. U, V, and W

These pins are the outputs of the three phases, and serve as the connection terminals to the 3-phase motor. These pins are the grounds of the high-side floating power supplies for each phase, and are connected to the negative nodes of bootstrap capacitors, C_{BOOTx} .

12.2.2. VB1, VB2, and VB3

These are the inputs of the high-side floating power supplies for the individual phases.

Voltages across the VBx and U/V/W pins should be maintained within the recommended range (i.e., the Logic Supply Voltage, V_{BS}) given in Section 2.

In each phase, a bootstrap capacitor, C_{BOOTx} , should be connected between the VBx and U/V/W pins. For proper startup, turn on the low-side transistor first, then fully charge the bootstrap capacitor, C_{BOOTx} . Table 12-1 shows a relation between the charging time and the capacitance of C_{BOOTx} at startup.

Table 12-1. C_{BOOTx} Capacitance vs. Charging Time at Startup

C_{BOOTx} Capacitance (μ F)	Reference Charging Time (s)
10	0.5
22	0.5
47	0.5
100	1.0
220	1.0

For the capacitance of the bootstrap capacitors, C_{BOOTx} , choose the values that satisfy Equations (1) and (2). Note that capacitance tolerance and DC bias characteristics must be taken into account when you choose appropriate values for C_{BOOTx} .

$$C_{BOOT} (\mu\text{F}) > 800 \times t_{L(OFF)} (\text{s}) \quad (1)$$

$$10 \mu\text{F} \leq C_{BOOTx} \leq 220 \mu\text{F} \quad (2)$$

In Equation (1), let $t_{L(OFF)}$ be the maximum off-time of the low-side transistor (i.e., the non-charging time of C_{BOOTx}), measured in seconds.

Even while the high-side transistor is off, voltage across the bootstrap capacitor keeps decreasing due to power dissipation in the IC. When the VBx pin voltage decreases to $V_{BS(OFF)}$ or less, the high-side undervoltage lockout (UVLO_VB) starts operating (see Section 12.4.2.1). Therefore, actual board checking should be done thoroughly to validate that voltage across the VBx pin maintains over 11.0 V ($V_{BS} > V_{BS(OFF)}$) during a low-frequency operation such as a startup period.

As Figure 12-1 shows, a bootstrap diode, D_{BOOTx} , and a current-limiting resistor, R_{BOOTx} , are internally placed in series between the VCC and VBx pins.

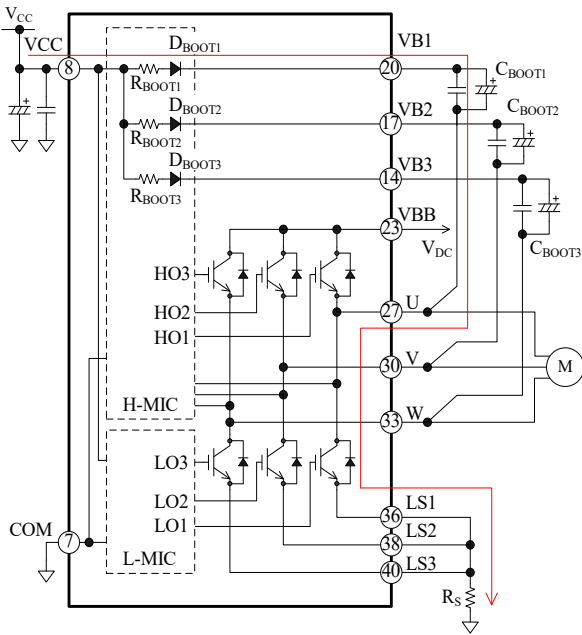

Figure 12-1. Bootstrap Circuit

Figure 12-2 shows an internal level-shifting circuit. A high-side output signal, Hox, is generated according to an input signal on the HINx pin. When an input signal on the HINx pin transits from low to high (rising edge), a “Set” signal is generated. When the HINx input signal transits from high to low (falling edge), a “Reset” signal is generated. These two signals are then transmitted to the high-side by the level-shifting circuit and are input to the SR flip-flop circuit. Finally, the SR flip-flop circuit feeds an output signal, Q (i.e., Hox).

Figure 12-3 is a timing diagram describing how noise or other detrimental effects will improperly influence the level-shifting process. When a noise-induced rapid voltage drop between the VBx and U/V/W pins (“VBx–U/V/W”) occurs after the Set signal generation, the next Reset signal cannot be sent to the SR flip-flop circuit. And the state of an Hox signal stays logic high (or “H”) because the SR flip-flop does not respond. With the Hox state being held high (i.e., the high-side transistor is in an on-state), the next LINx signal turns on the low-side transistor and causes a simultaneously-on condition, which may result in critical damage to the IC.

To protect the VBx pin against such a noise effect, add a bootstrap capacitor, C_BOOTx, in each phase. C_BOOTx must be placed near the IC and be connected between the VBx and U/V/W pins with a minimal length of traces.

To use an electrolytic capacitor, add a 0.01 μF to 0.1 μF bypass capacitor, C_Px, in parallel near these pins used for the same phase.

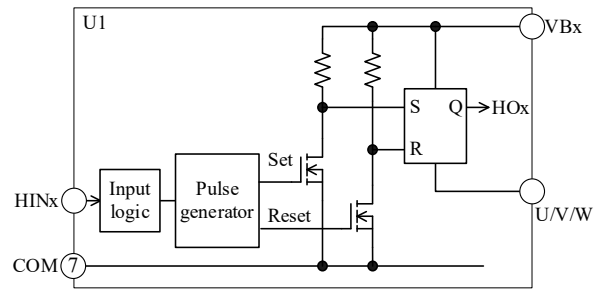

Figure 12-2. Internal Level-shifting Circuit

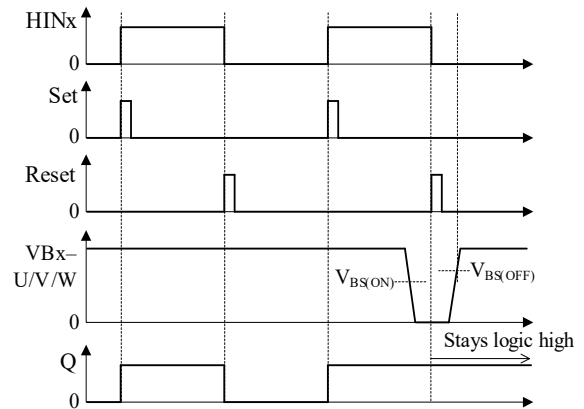

Figure 12-3. Waveforms at VBx–U/V/W Voltage Drop

12.2.3. VCC

This is the logic supply pin for the built-in control MICs. The VCC pin is internally connected to the high-side MIC and low-side MIC. To prevent malfunction induced by supply ripples or other factors, put a 0.01 μF to 0.1 μF ceramic capacitor, C_VCC, near this pin. To prevent damage caused by surge voltages, put an 18 V to 20 V Zener diode, DZ, between the VCC and COM pins.

Voltages to be applied between the VCC and COM pins should be regulated within the recommended operational range of V_{CC}, given in Section 2.

12.2.4. COM

This is the logic ground pin for the built-in control MICs. The COM pin is internally connected to the high-side MIC and low-side MIC. Varying electric potential of the logic ground can be a cause of improper operations. Therefore, connect the logic ground as close and short as possible to a shunt resistor, R_S, at a single-point ground (or star ground) which is separated from the power ground (see Figure 12-4). Moreover, extreme care should be taken in designing a PCB so that currents from the power ground do not affect the COM pin.

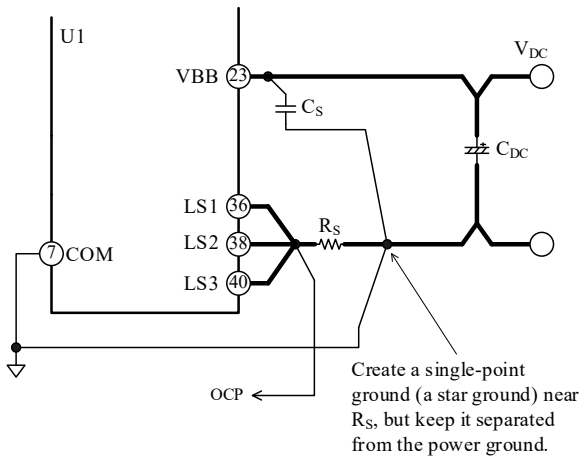

Figure 12-4. Connections to Logic Ground

12.2.5. HIN1, HIN2, and HIN3; LIN1, LIN2, and LIN3

These are the logic supply pins for the built-in control MICs. The HINx pin acts as a high-side controller; the LINx pin acts as a low-side controller. Figure 12-5 shows an internal circuit diagram of the HINx or LINx pin. This is a CMOS Schmitt trigger circuit with a built-in 22 kΩ pull-down resistor, and its input logic is active high.

Input signals across the HINx-COM and the LINx-COM pins in each phase should be set within the ranges provided in Table 12-2, below. Note that dead time setting must be done for HINx and LINx signals because the IC does not have a dead time generator.

The higher PWM carrier frequency rises, the more switching loss increases. Hence, the PWM carrier frequency must be set so that operational case temperatures and junction temperatures have sufficient margins against the absolute maximum ranges, specified in Section 1.

If the signals from the microcontroller become unstable, the IC may result in malfunctions. To avoid this event, the outputs from the microcontroller output line should not be high impedance. Also, if the traces from the microcontroller to the HINx or LINx pin (or both) are too long, the traces may be interfered by noise. Therefore, it is recommended to add an additional filter or a pull-down resistor near the HINx or LINx pin as needed (see Figure 12-6).

Here are filter circuit constants for reference:

- R_{IN1x}: 33 Ω to 100 Ω
- R_{IN2x}: 1 kΩ to 10 kΩ
- C_{INx}: 100 pF to 1000 pF

Care should be taken in adding R_{IN1x} and R_{IN2x} to the traces. When they are connected to each other, the input voltage of the HINx and LINx pins becomes slightly lower than the output voltage of the microcontroller.

Table 12-2. Input Signals for HINx and LINx Pins

Parameter	High Level Signal	Low Level Signal
Input Voltage	2.5 V < V _{IN} < 5.5 V	0 V < V _{IN} < 1.0 V
Input Pulse Width	≥0.5 μs	≥0.5 μs
PWM Carrier Frequency	≤20 kHz	
Dead Time	≥1.5 μs	

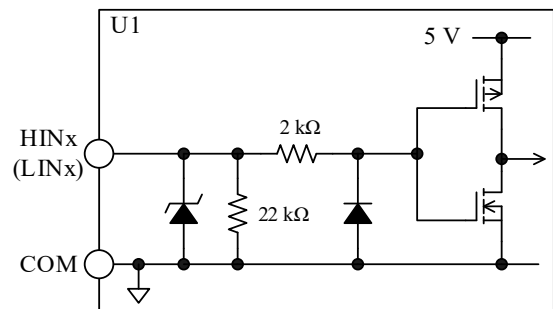

Figure 12-5. Internal Circuit Diagram of HINx or LINx Pin

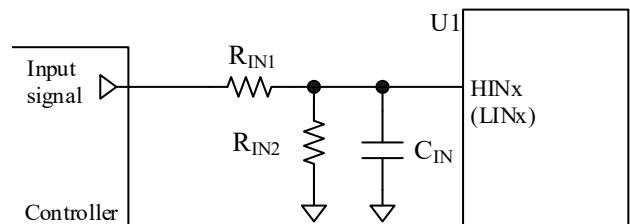

Figure 12-6. Filter Circuit for HINx or LINx Pin

12.2.6. VBB

This is the input pin for the main supply voltage, i.e., the positive DC bus. All of the IGBT collectors of the high-side are connected to this pin. Voltages between the VBB and COM pins should be set within the recommended range of the main supply voltage, V_{DC}, given in Section 2.

To suppress surge voltages, put a 0.01 μF to 0.1 μF bypass capacitor, C_s, near the VBB pin and an electrolytic capacitor, C_{DC}, with a minimal length of PCB traces to the VBB pin.

12.2.7. LS1, LS2, and LS3

These are the emitter pins of the low-side IGBTs and are externally connected to a shunt resistor, R_s.

When connecting a shunt resistor, use a resistor with

low inductance, and place it as near as possible to the IC with a minimum length of traces to the LSx and COM pins. Otherwise, malfunction may occur because a longer circuit trace increases its inductance and thus increases its susceptibility to improper operations. In applications where long PCB traces are required, add a fast recovery diode, D_{RS} , between the LSx and COM pins in order to prevent the IC from malfunctioning.

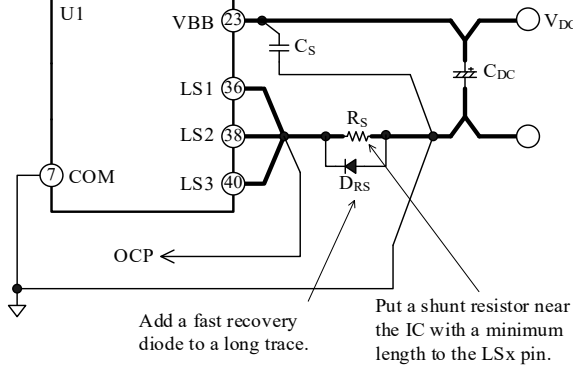

Figure 12-7. Connections to LSx Pin

12.2.8. OCP

This pin serves as the input of the overcurrent protection (OCP) for monitoring the currents going through the output transistors. Section 12.4.3 provides further information about the OCP circuit configuration and its mechanism.

12.2.9. FO

This pin operates as the fault signal output. For more details, see Section 12.4.1.

Figure 12-8 illustrates an internal circuit diagram of the FO pin and its peripheral circuit. The 100 kΩ pull-up resistor is connected to the FO pin in the internal circuit, but the FO pin should be tied by a pull-up resistor, R_{FO} , to the external power supply to suppress the noise effect. The external power supply voltage (i.e., the FO Pin Pull-up Voltage, V_{FO}) should range from 3.3 V to 5.5 V. The filter capacitor of the FO pin, C_{FO} , should have a capacitance of $\leq 0.01 \mu\text{F}$.

Figure 12-10 shows a relation between the FO pin voltage and the pull-up resistor, R_{FO} . When the pull-up resistor, R_{FO} , has a too small resistance, the FO pin voltage at fault signal output becomes high due to the on-resistance of a built-in transistor, Q_{FO} (Figure 12-8). Therefore, it is recommended to use a 3.3 kΩ to 10 kΩ pull-up resistor when the Low Level Input Threshold Voltage of the microcontroller, V_{IL} , is set to 1.0 V.

To suppress noise, add a filter capacitor, C_{FO} , near the IC with minimizing a trace length between the FO and COM pins. Note that, however, this additional filtering allows a delay time to occur, as seen in Figure 12-9. The

delay time is a period of time which starts when the IC receives a fault flag turning on the internal transistor, Q_{FO} , and continues until when the FO pin reaches its threshold voltage (V_{IL}) of 1.0 V or below (put simply, until the time when the IC detects a low state, “L”). Figure 12-11 shows the relationship between C_{FO} and the FO pin delay time. For avoiding repeated OCP activations, the external microcontroller must shut off any input signals to the IC within a fixed hold time, t_p , after the internal transistor (Q_{FO}) turn-on. T_p is 5 ms where minimum values of thermal characteristics are taken into account (for more details, see Section 12.4.3). When $V_{IL} = 1.0 \text{ V}$, the reference value of C_{FO} is 0.001 μF to 0.01 μF .

Motor operation must be controlled by the external microcontroller so that it can immediately stop the motor when fault signals are detected. To resume the motor operation thereafter, set the motor to be resumed after a lapse of ≥ 2 seconds.

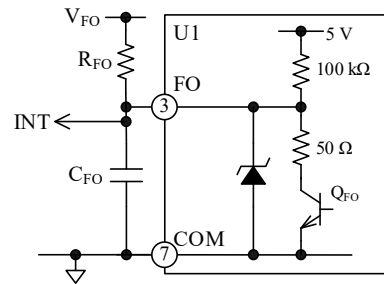

Figure 12-8. Internal Circuit Diagram of FO Pin and Its Peripheral Circuit

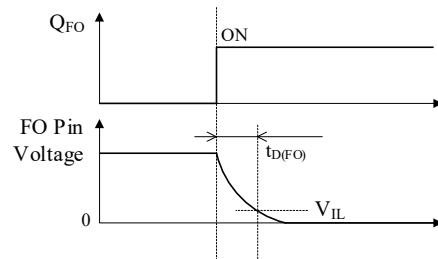

Figure 12-9. FO Pin Delay Time, $t_{D(FO)}$

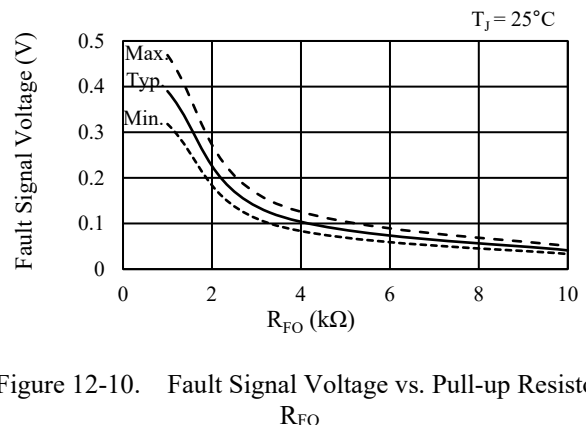

Figure 12-10. Fault Signal Voltage vs. Pull-up Resistor, R_{FO}

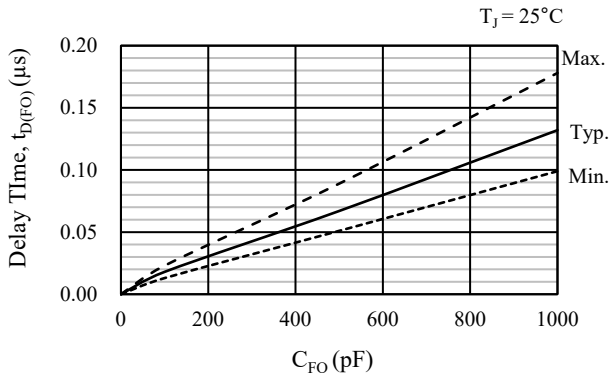

Figure 12-11. Filter Capacitor, C_{FO} vs. FO Pin Delay Time, t_{D(FO)}

12.2.10. VT

This pin outputs temperature sensing voltages. The external microcontroller can monitor the junction temperature of the internal control IC, not of the output transistors, with the VT pin. For more details, see Section 12.3.

12.3. Temperature Sensing Function

The microcontroller can monitor the junction temperature of the internal control IC, through temperature sensing voltages that the VT pin outputs. The SIM2-151A does not include any protections against overtemperature, such as an IC shutdown or a fault flag. Therefore, the IC must be set to stop its operation as it detects an abnormal heating state with temperature sensing voltages. A typical example is turning off input signals from the microcontroller. Figure 12-13 shows a relation between the VT pin voltage and temperature. Table 12-3 and Table 12-4 provide the details of variations found in Figure 12-13.

Temperature sensing voltages may exceed 3.0 V, causing permanent damage to the IC in the worst case. To protect the parts connected to the VT pin such as the microcontroller, add a clamp diode, D_{VT}, between the microcontroller power supply and the VT pin (see Figure 12-12).

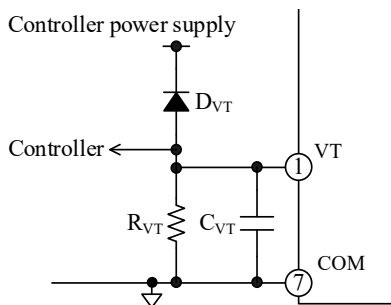

Figure 12-12. VT Pin Peripheral Circuit

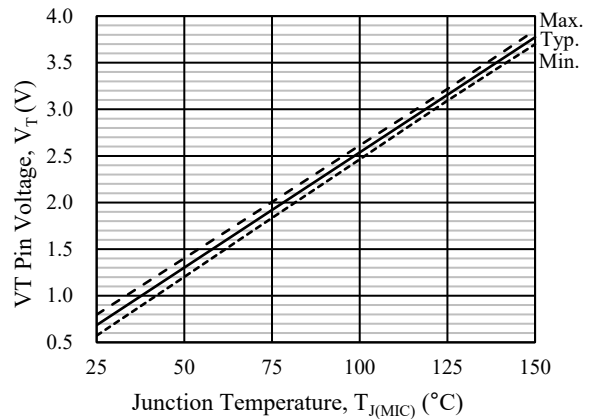

Figure 12-13. VT Pin Voltage, V_T vs. Internal Control IC Junction Temperature, T_{J(MIC)} (Design Value)

Table 12-3. T_{J(MIC)} Variation on VT Pin Voltage (Design Value)

VT Pin Voltage (V)	T _{J(MIC)} (°C)
1.271	50 ± 3
3.130	125 ± 2

Table 12-4. VT Pin Voltage Variation on T_{J(MIC)} (Design Value)

T _{J(MIC)} (°C)	VT Pin Voltage (V)
50	1.271 ± 0.07
125	3.130 ± 0.05

12.4. Protection Functions

This section describes the various protection circuits provided in the SIM2-151A. The protection circuits include the undervoltage lockout for power supplies (UVLO), the overcurrent protection (OCP), and the thermal shutdown (TSD). In case one or more of these protection circuits are activated, the FO pin outputs a fault signal; as a result, the external microcontroller can stop the operations of the three phases by receiving the fault signal. In the following functional descriptions, “Hox” denotes a gate input signal on the high-side transistor, whereas “Lox” denotes a gate input signal on the low-side transistor (see also the diagram in Section 7). “VBx-U/V/W” refers to the voltages between the VBx and U/V/W pins.

12.4.1. Fault Signal Output

In case one or more of the following protections are actuated, an internal transistor, Q_{FO} , turns on, then the FO pin becomes logic low (≤ 0.5 V).

- 1) Low-side undervoltage lockout (UVLO_VCC)
- 2) Overcurrent protection (OCP)
- 3) Thermal shutdown (TSD)

While the FO pin is in the low state, the low-side transistors of each phase turn off. In normal operation, the FO pin outputs a high signal of about 5 V. The fault signal output time of the FO pin at OCP activation is the hold time, $t_P = 10$ ms (typ.), fixed by a built-in feature of the IC itself (see Section 12.4.3). The external microcontroller receives the fault signals with its interrupt pin (INT), and must be programmed to put the HIN_x and LIN_x pins to logic low within the predetermined hold time, t_P . To resume motor operations thereafter, set the motor to be resumed after a lapse of ≥ 2 seconds.

12.4.2. Undervoltage Lockout for Power Supply (UVLO)

In case the gate-driving voltages of the output transistors decrease, their steady-state power dissipations increase. This overheating condition may cause permanent damage to the IC in the worst case. To prevent this event, the SIM2-151A has the undervoltage lockout (UVLO) circuits for both of the high- and low-side power supplies.

12.4.2.1. Undervoltage Lockout for High-side Power Supply (UVLO_VB)

Figure 12-14 shows operational waveforms of the undervoltage lockout for high-side power supply (i.e., UVLO_VB).

When the voltage between the VB_x and U/V/W pins ($V_{Bx-U/V/W}$) decreases to the Logic Operation Stop Voltage ($V_{BS(OFF)} = 10.0$ V) or less, the UVLO_VB circuit in the corresponding phase gets activated and sets an HO_x signal to logic low.

When the voltage between the VB_x and U/V/W pins increases to the Logic Operation Start Voltage ($V_{BS(ON)} = 10.5$ V) or more, the IC releases the UVLO_VB condition. Then, the HO_x signal becomes logic high at the rising edge of the first input command after the UVLO_VB release. Any fault signal is not output from the FO pin during the UVLO_VB operation. In addition, the VB_x pin has an internal UVLO_VB filter of about 3 μ s, in order to prevent noise-induced malfunctions.

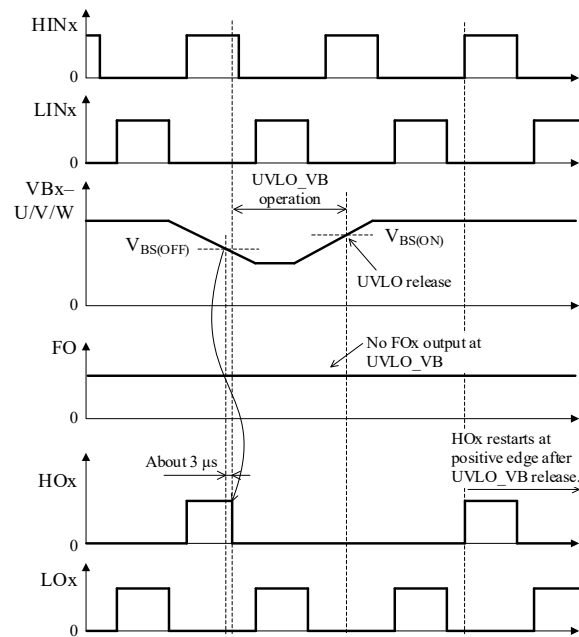

Figure 12-14. UVLO_VB Operational Waveforms

12.4.2.2. Undervoltage Lockout for Low-side Power Supply (UVLO_VCC)

The VCC pin has the VCC pin undervoltage lockout (UVLO_VCC) circuit for low-side power supply.

The description hereafter provides the UVLO_VCC operation of the VCC pin. As Figure 12-15 shows, when the VCC pin voltage decreases to the Logic Operation Stop Voltage ($V_{CC(OFF)} = 11.0$ V) or less, the UVLO_VCC circuit in the U-phase gets activated and sets both of HO1 and LO1 signals to logic low. When the VCC pin voltage increases to the Logic Operation Start Voltage ($V_{CC(ON)} = 11.5$ V) or more, the IC releases the UVLO_VCC operation. Then it resumes transmitting the HO1 and LO1 signals according to input commands on the HIN1 and LIN1 pins. During the UVLO_VCC operation, the FO pin becomes logic low and sends fault signal. In addition, the VCC pin has an internal UVLO_VCC filter of about 3 μ s, in order to prevent noise-induced malfunctions.

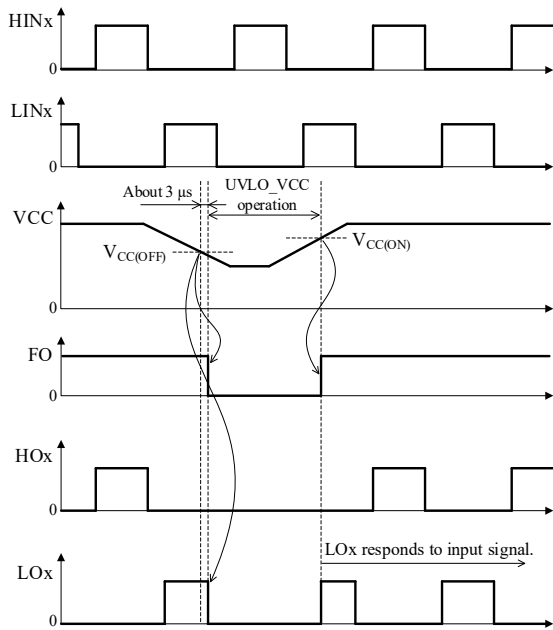

Figure 12-15. UVLO_VCC Operational Waveforms

12.4.3. Overcurrent Protection (OCP)

The OCP pin has the overcurrent protection (OCP) circuit. Figure 12-16 is an internal circuit diagram describing the OCP pin and its peripheral circuit.

The OCP pin detects overcurrents with voltage across an external shunt resistor, R_S . Because the OCP pin is internally pulled down, the OCP pin voltage increases proportionally to a rise in the current running through the shunt resistor, R_S .

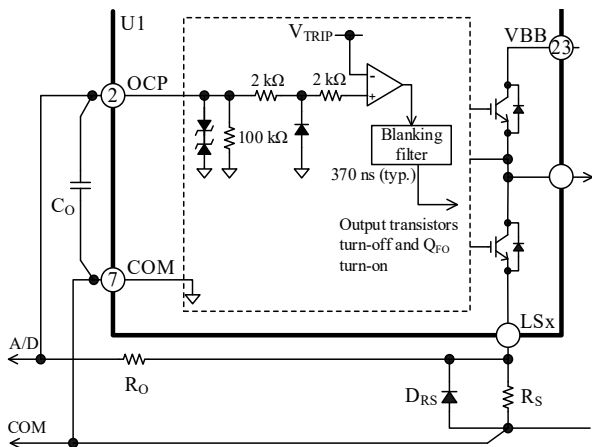

Figure 12-16. Internal Circuit Diagram of OCP Pin and Its Peripheral Circuit

Figure 12-17 shows operational waveforms when the OCP pin detects an overcurrent condition. When the OCP pin voltage increases to the OCP Threshold

Voltage ($V_{TRIP} = 0.50\text{ V}$) or more, and remains in this condition for a period of the OCP Blanking Time ($t_{BK(OCP)} = 370\text{ ns}$) or longer, the corresponding OCP circuit is activated. When an internal delay time ($t_{D(OCP)} = 0.13\text{ μs}$) has elapsed after the OCP activation, the low-side output transistors turn off and the FO pin becomes low state. Then, output current decreases as a result of the low-side output transistor turn-offs. Even if the OCP pin voltage falls below V_{TRIP} , the IC holds the FO pin in the low state for a fixed hold time, $t_p = 10\text{ ms}$. Then, the output transistors operate according to input signals.

To prevent noise-induced malfunctions, connect a ceramic capacitor, C_{FO} (about 0.001 μF to 0.1 μF) to the FO pin.

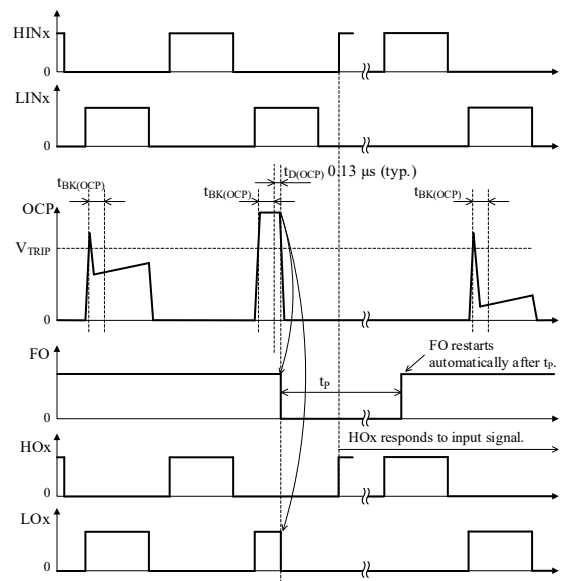

Figure 12-17. OCP Operational Waveforms

The OCP is used for detecting abnormal conditions, such as an output transistor shorted. In case short-circuit conditions occur repeatedly, the output transistors can be destroyed. To prevent such event, motor operation must be controlled by the external microcontroller so that it can immediately stop the motor when fault signals are detected.

The external microcontroller receives the fault signals with its interrupt pin (INT), and must be programmed to put the HINx and LINx pins to logic low within the predetermined hold time, t_p . To resume motor operations thereafter, set the motor to be resumed after a lapse of ≥ 2 seconds.

For proper shunt resistor setting, your application must meet the following:

- Use the shunt resistor that has a recommended resistance, R_S (see Section 2).
- Set the OCP pin input voltage to vary within the rated OCP pin voltages, V_{OCP} (see Section 1).

- Keep the current through the output transistors below the rated output current (pulse), I_{OP} (see Section 1).

It is required to use a resistor with low internal inductance because high-frequency switching current will flow through the shunt resistor, R_S . In addition, choose a resistor with allowable power dissipation according to your application.

When you connect a CR filter (i.e., a pair of a filter resistor, R_O , and a filter capacitor, C_O) to the OCP pin, care should be taken in setting the time constants of R_O and C_O . The larger the time constant, the longer the time that the OCP pin voltage rises to V_{TRIP} . And this may cause permanent damage to the transistors. Consequently, a propagation delay of the IC must be taken into account when you determine the time constants. For R_O and C_O , their time constants must be set to $\leq 1.0 \mu s$. The filter capacitor, C_O , should also be placed near the IC, between the OCP and COM pins with a minimal length of traces.

Note that overcurrents are undetectable when one or more of the U, V, and W pins or their traces are shorted to ground (ground fault). In case any of these pins falls into a state of ground fault, the output transistors may be destroyed.

12.4.4. Thermal Shutdown (TSD)

The SIM2-151A incorporates the thermal shutdown (TSD) circuit in the low-side MIC (see Section 7). The TSD circuit protects the IC from overheating, such as increased power dissipation due to overload, or elevated ambient temperature at the device. When the temperature of the low-side MIC exceeds the TSD Operating Temperature ($T_{DH} = 120 \text{ }^\circ\text{C}$) due to such overheating, the TSD circuit is activated. During the TSD operation, the IC turns off the low-side output transistors and outputs a fault signal (see Figure 12-18).

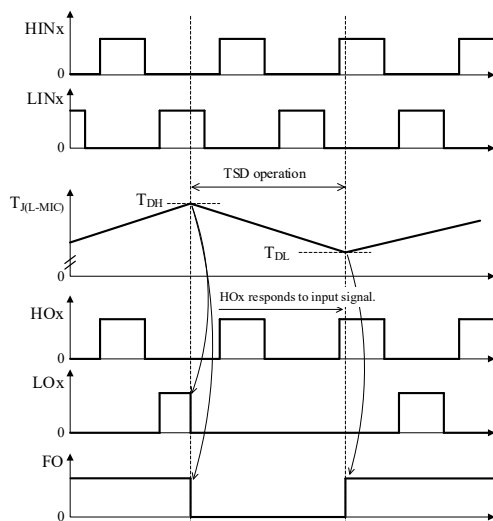

Figure 12-18. TSD Operational Waveforms

When the temperature of the low-side MIC decreases to the TSD Releasing Temperature ($T_{DL} = 100 \text{ }^\circ\text{C}$) or less thereafter, the shutdown condition is released. The output transistors then resume operating according to input signals. Also note that junction temperatures of the output transistors themselves are not monitored; therefore, do not use the TSD function as an overtemperature prevention for the output transistors.

13. Design Notes

This section also employs the notation system described in the beginning of the previous section.

13.1. PCB Pattern Layout

Figure 13-1 shows a schematic diagram of a motor drive circuit. The circuit consists of current paths having high frequencies and high voltages, which also bring about negative influences on IC operation, noise interference, and power dissipation. Therefore, PCB trace layouts and component placements play an important role in circuit designing. Current loops, which have high frequencies and high voltages, should be as small and wide as possible, in order to maintain a low-impedance state. In addition, ground traces should be as wide and short as possible so that radiated EMI levels can be reduced.

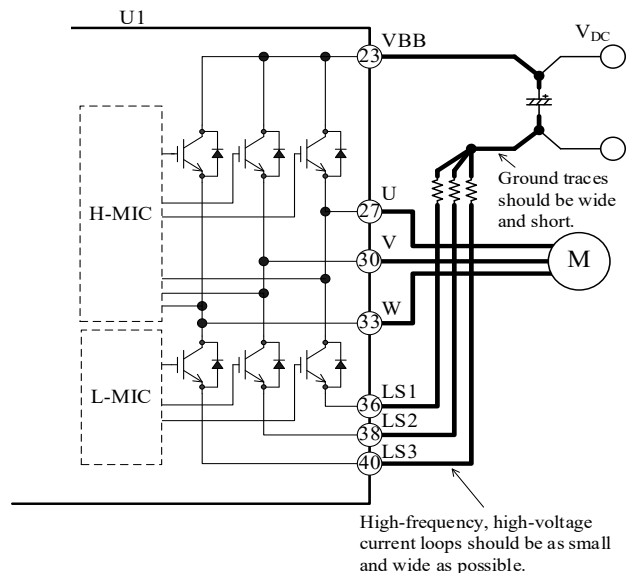

Figure 13-1. High-frequency, High-voltage Current Paths

13.2. Considerations in Heatsink Mounting

The following are the key considerations and the guidelines for mounting a heatsink:

- Be sure to use a metric screw of M3 and a plain washer of 7 mm (ϕ). When tightening the screws, use a torque screwdriver and tighten them within the range of screw torque defined in Section 4. Be sure to avoid uneven tightening. Temporarily tighten the two screws first, then tighten them equally on both sides until the specified screw torque is reached.
- When mounting a heatsink, it is recommended to use silicone greases. If a thermally conductive sheet or an electrically insulating sheet is used, package cracks may be occurred due to creases at screw tightening. Therefore, you should conduct thorough evaluations before using these materials.
- When applying a silicone grease, make sure that there are no foreign substances between the IC and a heatsink. Extreme care should be taken not to apply a silicone grease onto any device pins as much as possible. The following requirements must be met for proper grease application:
 - Grease thickness: 100 μm
 - Heatsink flatness: $\pm 100 \mu\text{m}$
 - Apply a silicone grease within the area indicated in Figure 13-2, below.

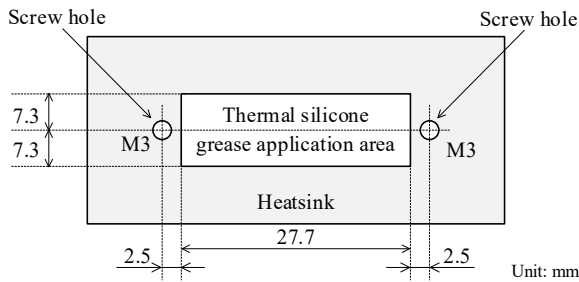

Figure 13-2. Reference Application Area for Thermal Silicone Grease

13.3. Considerations in IC Characteristics Measurement

When measuring the breakdown voltage or leakage current of the transistors incorporated in the IC, note that the gate and emitter of each transistor should have the same potential. Moreover, care should be taken during the measurement because the collectors of the high-side transistors are all internally connected to the VBB pin.

The output (U, V, and W) pins are connected to the emitters of the corresponding high-side transistors, whereas the LSx pins are connected to the emitters of the low-side transistors. The gates of the high-side transistors are pulled down to the corresponding output (U, V, and W) pins; similarly, the gates of the low-side transistors are pulled down to the COM pin.

When measuring the breakdown voltage or leakage current of the transistors incorporated in the IC, note that all of the output (U, V, and W), LSx, and COM pins must be appropriately connected. Otherwise, the output

transistors may result in permanent damage.

The following are circuit diagrams representing typical measurement circuits for breakdown voltage: Figure 13-3 shows the high-side transistor (Q_{1H}) in the U-phase; Figure 13-4 shows the low-side transistor (Q_{1L}) in the U-phase. And all the pins that are not represented in these figures are open.

Before conducting a measurement, be sure to isolate the ground of the to-be-measured phase from those of other two phases not to be measured. Then, in each of the two phases, which are separated not to be measured, connect the LSx and COM pins each other at the same potential, and leave them unused and floated.

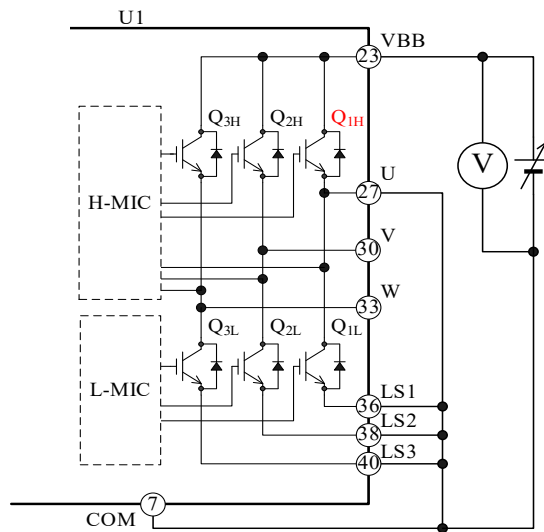

Figure 13-3. Typical Measurement Circuit for High-side Transistor (Q_{1H}) in U-phase

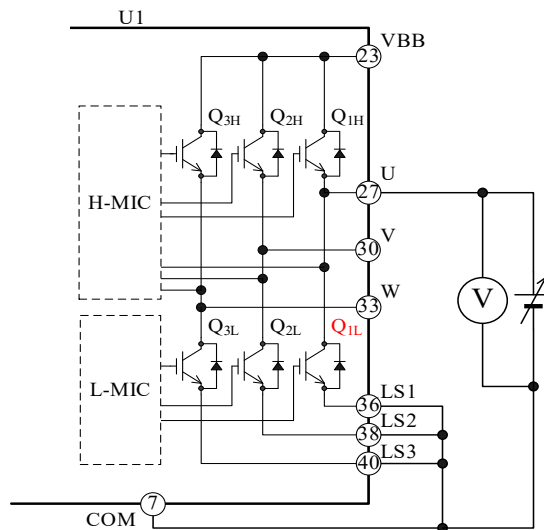

Figure 13-4. Typical Measurement Circuit for Low-side Transistor (Q_{1L}) in U-phase

14. Calculating Power Losses and Estimating Junction Temperature

This section describes the procedures to calculate power losses in an output transistor, and to estimate a junction temperature (in 1-element operation). Note that the descriptions listed here are applicable to the SIM2-151A, which is controlled by a 3-phase sine-wave PWM driving strategy.

For quick and easy references, we offer calculation support tools online. Please visit our website to find out more.

- DT0106: SIM2-151A Calculation Tool
https://www.semicon.sanken-ele.co.jp/en/calc-tool/igbt1_caltool2_en.html

Total power loss in an output transistor can be obtained by taking the sum of IGBT steady-state loss, P_{ON} , IGBT switching loss, P_{SW} , and freewheeling diode steady-state loss, P_F . The following subsections contain the mathematical procedures to calculate these losses (P_{ON} , P_{SW} , and P_F) and the junction temperature of an IGBT and freewheeling diode operating.

14.1. IGBT Steady-state Loss, P_{ON}

Steady-state loss in an IGBT can be computed by using the $V_{CE(SAT)}$ vs. I_C curves, listed in Section 15.2.1. As expressed by the curves in Figure 14-1, a linear approximation at a range the I_C is actually used is obtained by: $V_{CE(SAT)} = \alpha \times I_C + \beta$.

The values gained by the above calculation are then applied as parameters in Equation (3), below. Hence, the equation to obtain the IGBT steady-state loss, P_{ON} , is:

$$\begin{aligned}
 P_{ON} &= \frac{1}{2\pi} \int_0^\pi V_{CE(SAT)}(\varphi) \times I_C(\varphi) \times DT \times d\varphi \\
 &= \frac{1}{2} \alpha \left(\frac{1}{2} + \frac{4}{3\pi} M \times \cos\theta \right) I_M^2 \\
 &\quad + \frac{\sqrt{2}}{\pi} \beta \left(\frac{1}{2} + \frac{\pi}{8} M \times \cos\theta \right) I_M. \quad (3)
 \end{aligned}$$

Where:

- $V_{CE(SAT)}$ is the collector-to-emitter saturation voltage of the IGBT (V),
- I_C is the collector current of the IGBT (A),
- DT is the duty cycle, which is given by

$$DT = \frac{1 + M \times \sin(\varphi + \theta)}{2},$$

- M is the modulation index (0 to 1),
- $\cos\theta$ is the motor power factor (0 to 1),

I_M is the effective motor current (A),
 α is the slope of the linear approximation in the $V_{CE(SAT)}$ vs. I_C curve, and
 β is the intercept of the linear approximation in the $V_{CE(SAT)}$ vs. I_C curve.

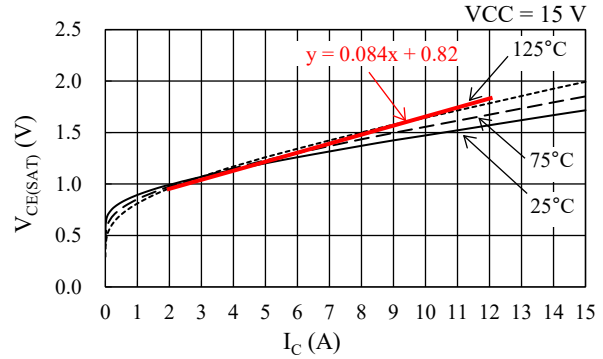

Figure 14-1. Linear Approximate Equation of $V_{CE(SAT)}$ vs. I_C

14.2. IGBT Switching Loss, P_{SW}

Switching loss in an IGBT, P_{SW} , can be calculated by Equation (4), letting I_M be the effective current value of the motor:

$$P_{SW} = \frac{\sqrt{2}}{\pi} \times f_C \times \alpha_E \times I_M \times \frac{V_{DC}}{300}. \quad (4)$$

Where:

- f_C is the PWM carrier frequency (Hz),
- V_{DC} is the main power supply voltage (V), i.e., the VBB pin input voltage, and
- α_E is the slope of the switching loss curve (see Section 15.2.2).

14.3. Estimating Junction Temperature of IGBT

The junction temperature of an IGBT operating, T_J , can be estimated with Equation (5):

$$T_J = R_{(J-C)Q} \times (P_{ON} + P_{SW}) + T_C. \quad (5)$$

Where:

- $R_{(J-C)Q}$ is the junction-to-case thermal resistance per IGBT ($^{\circ}C/W$), and
- T_C is the case temperature ($^{\circ}C$), measured at the point defined in Figure 3-1.

14.4. Freewheeling Diode Steady-state Loss, P_F

Steady-state loss in a freewheeling diode can be computed by using the V_F vs. I_F curves, listed in Section 15.2.1. As expressed by the curves in Figure 14-2, a linear approximation at a range the I_F is actually used is obtained by: V_F = α × I_F + β.

The values gained by the above calculation are then applied as parameters in Equation (6), below. Hence, the equation to obtain the freewheeling diode steady-state loss, P_F, is:

$$P_F = \frac{1}{2\pi} \int_0^\pi V_F(\varphi) \times I_F(\varphi) \times (1 - DT) \times d\varphi$$

$$= \frac{1}{2} \alpha \left(\frac{1}{2} - \frac{4}{3\pi} M \times \cos \theta \right) I_M^2 + \frac{\sqrt{2}}{\pi} \beta \left(\frac{1}{2} - \frac{\pi}{8} M \times \cos \theta \right) I_M \quad (6)$$

Where:

V_F is the forward voltage of the freewheeling diode (V),

I_F is the forward current of the freewheeling diode (A),

DT is the duty cycle, which is given by

$$DT = \frac{1 + M \times \sin(\varphi + \theta)}{2},$$

M is the modulation index (0 to 1),

cosθ is the motor power factor (0 to 1),

I_M is the effective motor current (A),

α is the slope of the linear approximation in the V_F vs. I_F curve, and

β is the intercept of the linear approximation in the V_F vs. I_F curve.

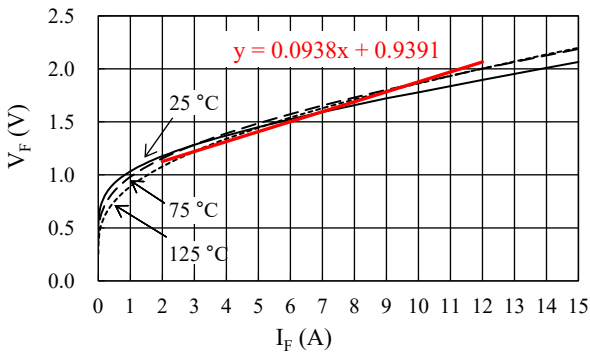

Figure 14-2. Linear Approximate Equation of V_F vs. I_F

14.5. Estimating Junction Temperature of Freewheeling Diode

The junction temperature of a freewheeling diode operating, T_J, can be estimated with Equation (7):

$$T_J = R_{(J-C)F} \times P_F + T_C \quad (7)$$

Where:

R_{(J-C)F} is the junction-to-case thermal resistance per freewheeling diode (°C/W), and

T_C is the case temperature (°C), measured at the point defined in Figure 3-1.

15. Performance Curves

15.1. Performance Curves of Control Parts

Figure 15-1 to Figure 15-20 provide performance curves of the control parts integrated in the SIM2-151A, including variety-dependent characteristics and thermal characteristics. T_J represents the junction temperature of the control parts.

Table 15-1. Typical Characteristics of Control Parts

Figure Number	Figure Caption
Figure 15-1	Logic Supply Current in 3-phase Operation, I_{CC} vs. T_C
Figure 15-2	Logic Supply Current in 3-phase Operation, I_{CC} vs. VCC Pin Voltage, V_{CC}
Figure 15-3	Logic Supply Current in 1-phase Operation ($HIN_x = 0$ V), I_{BS} vs. T_C
Figure 15-4	Logic Supply Current in 1-phase Operation ($HIN_x = 5$ V), I_{BS} vs. T_C
Figure 15-5	Logic Supply Current in 1-phase Operation ($HIN_x = 0$ V), I_{BS} vs. VBx Pin Voltage, V_B
Figure 15-6	Logic Operation Start Voltage, $V_{BS(ON)}$ vs. T_C
Figure 15-7	Logic Operation Stop Voltage, $V_{BS(OFF)}$ vs. T_C
Figure 15-8	Logic Operation Start Voltage, $V_{CC(ON)}$ vs. T_C
Figure 15-9	Logic Operation Stop Voltage, $V_{CC(OFF)}$ vs. T_C
Figure 15-10	UVLO VB Filtering Time vs. T_C
Figure 15-11	UVLO VCC Filtering Time vs. T_C
Figure 15-12	Input Current at High Level (HIN_x or LIN_x), I_{IN} vs. T_C
Figure 15-13	High Level Input Signal Threshold Voltage, V_{IH} vs. T_C
Figure 15-14	Low Level Input Signal Threshold Voltage, V_{IL} vs. T_C
Figure 15-15	Minimum Transmittable Pulse Width for High-side Switching, $t_{HIN(MIN)}$ vs. T_C
Figure 15-16	Minimum Transmittable Pulse Width for Low-side Switching, $t_{LIN(MIN)}$ vs. T_C
Figure 15-17	FO Pin Voltage in Normal Operation, V_{FOL} vs. T_C
Figure 15-18	OCP Threshold Voltage, V_{TRIP} vs. T_C
Figure 15-19	OCP Blanking Time, $t_{BK(OCP)}$ + Propagation Delay, $t_{D(OCP)}$ vs. T_C
Figure 15-20	OCP Hold Time, t_P vs. T_C

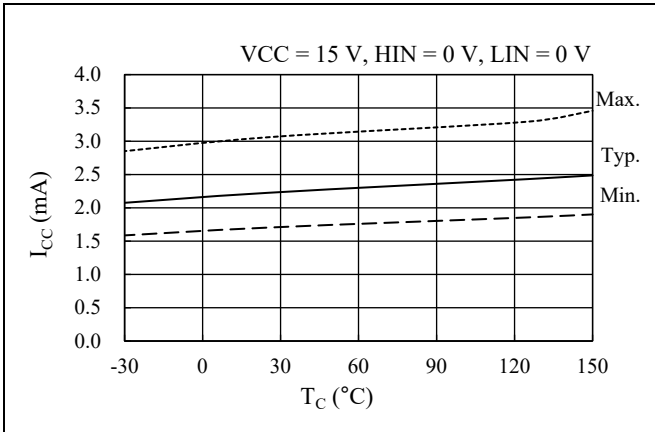

Figure 15-1. Logic Supply Current in 3-phase Operation, I_{CC} vs. T_C

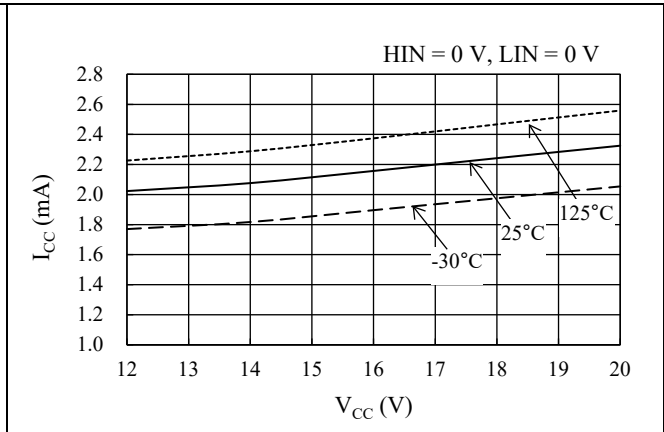

Figure 15-2. Logic Supply Current in 3-phase Operation, I_{CC} vs. V_{CC} Pin Voltage, V_{CC}

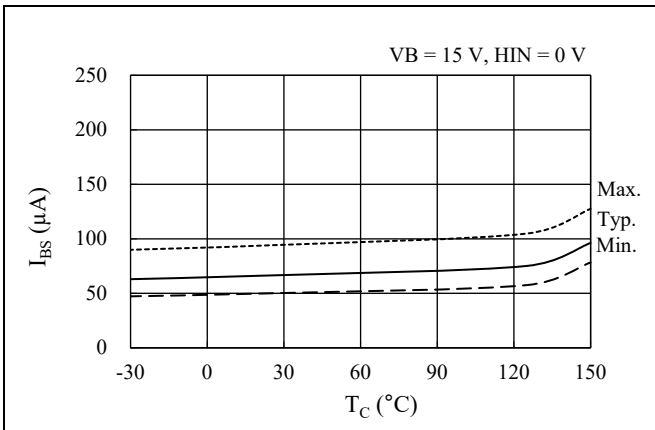

Figure 15-3. Logic Supply Current in 1-phase Operation ($HIN_x = 0 V$), I_{BS} vs. T_C

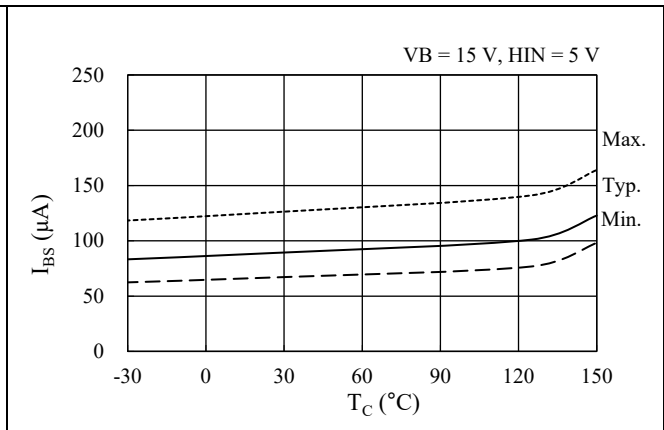

Figure 15-4. Logic Supply Current in 1-phase Operation ($HIN_x = 5 V$), I_{BS} vs. T_C

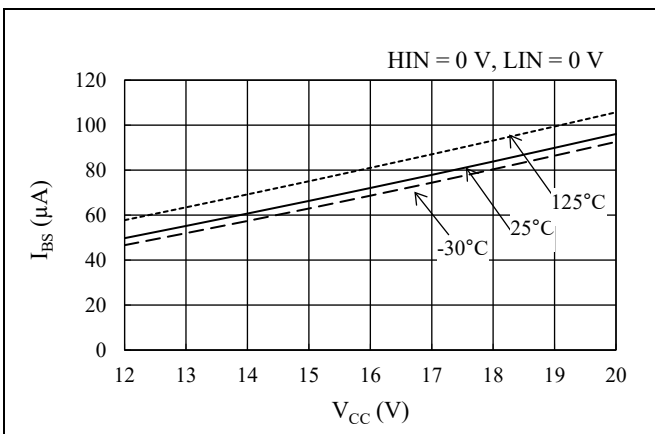

Figure 15-5. Logic Supply Current in 1-phase Operation ($HIN_x = 0 V$), I_{BS} vs. V_{Bx} Pin Voltage, V_B

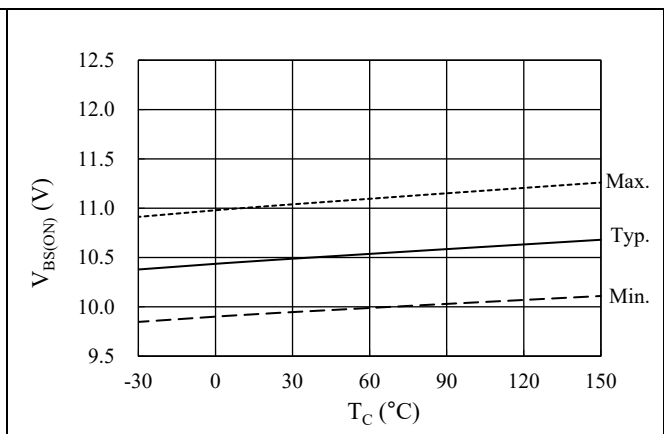

Figure 15-6. Logic Operation Start Voltage, $V_{BS(ON)}$ vs. T_C

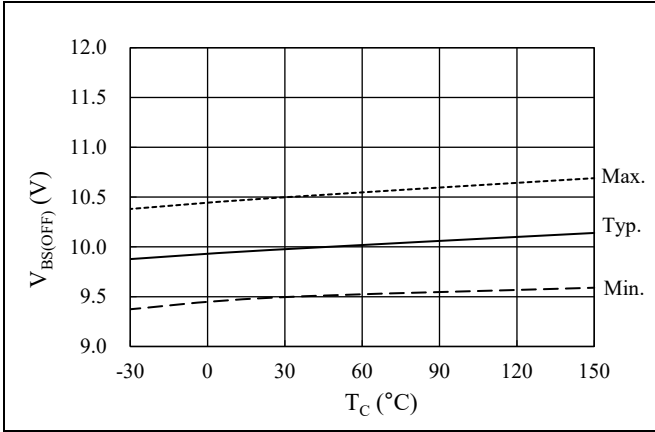

Figure 15-7. Logic Operation Stop Voltage, $V_{BS(OFF)}$ vs. T_C

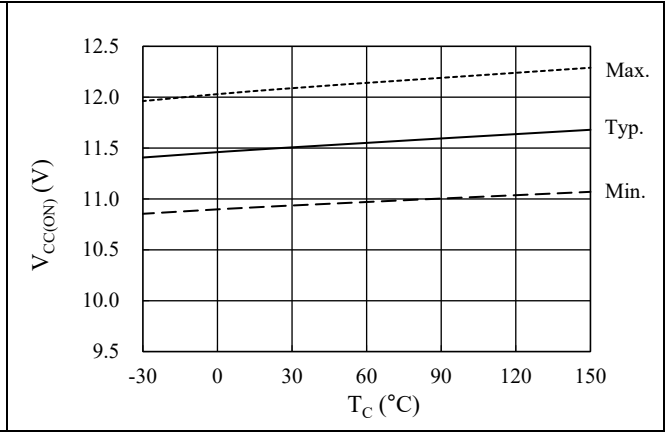

Figure 15-8. Logic Operation Start Voltage, $V_{CC(ON)}$ vs. T_C

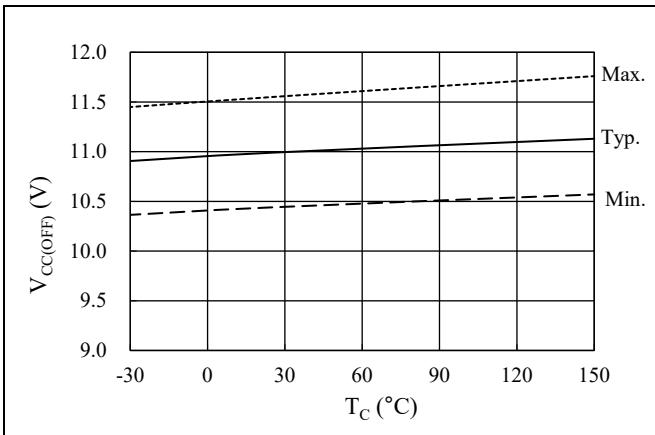

Figure 15-9. Logic Operation Stop Voltage, $V_{CC(OFF)}$ vs. T_C

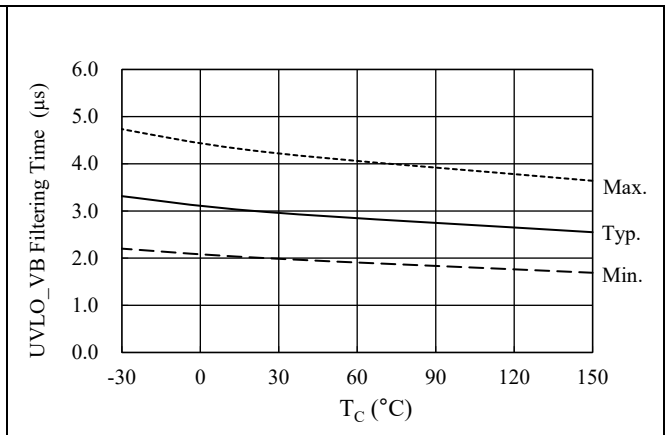

Figure 15-10. UVLO_VB Filtering Time vs. T_C

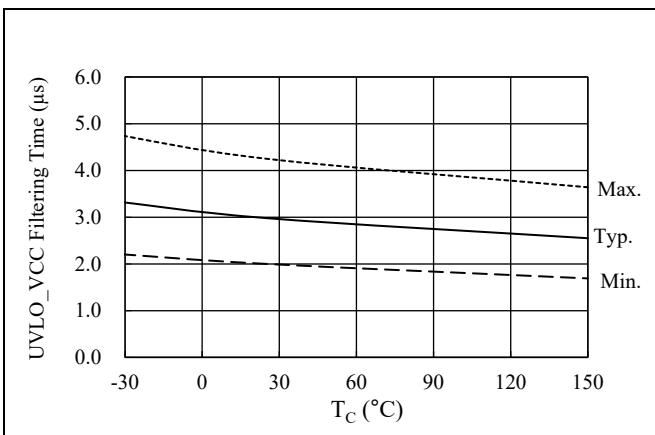

Figure 15-11. UVLO_VCC Filtering Time vs. T_C

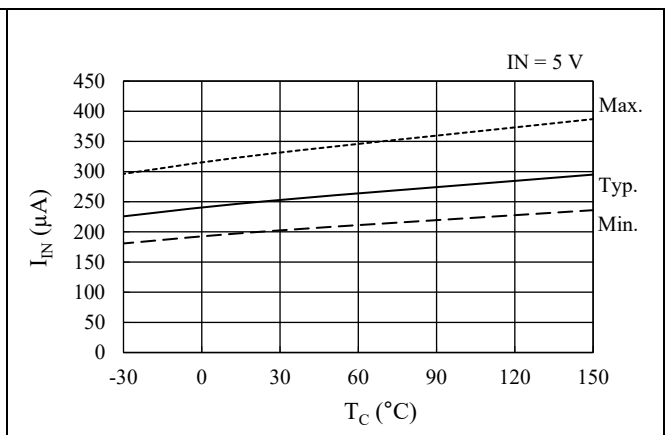

Figure 15-12. Input Current at High Level (HINx or LINx), I_{IN} vs. T_C

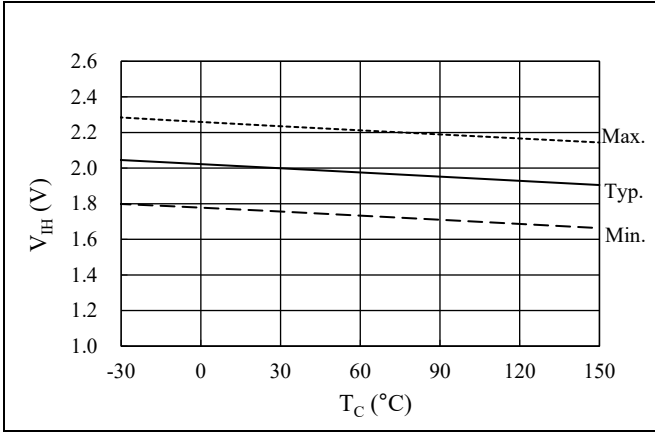

Figure 15-13. High Level Input Signal Threshold Voltage, V_{IH} vs. T_C

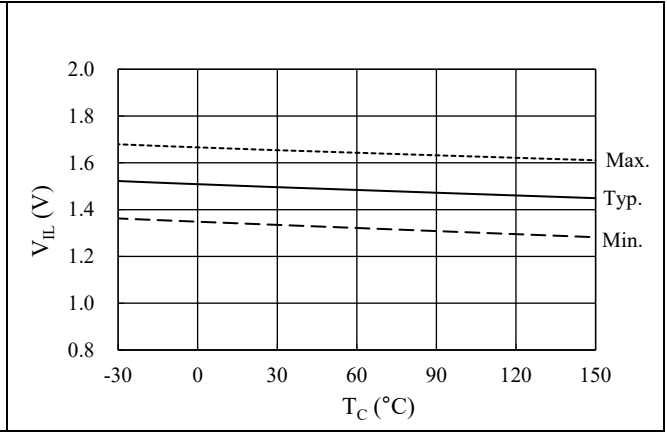

Figure 15-14. Low Level Input Signal Threshold Voltage, V_{IL} vs. T_C

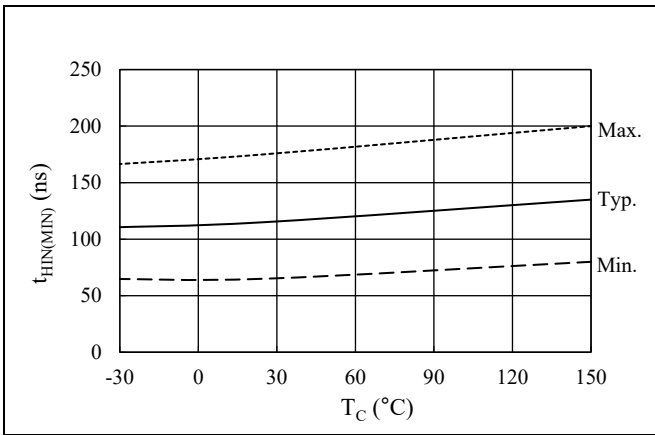

Figure 15-15. Minimum Transmittable Pulse Width for High-side Switching, $t_{HI(MIN)}$ vs. T_C

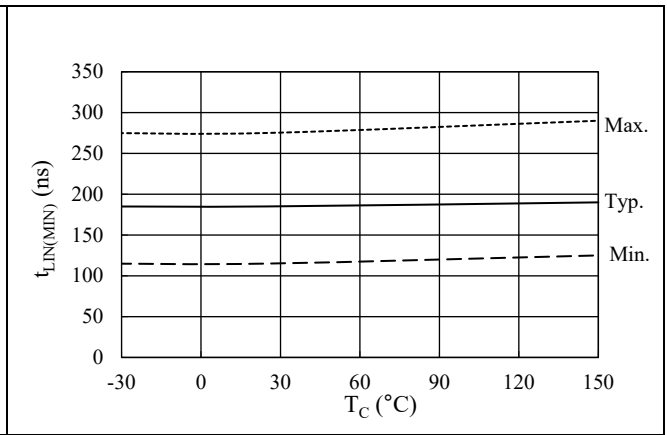

Figure 15-16. Minimum Transmittable Pulse Width for Low-side Switching, $t_{LI(MIN)}$ vs. T_C

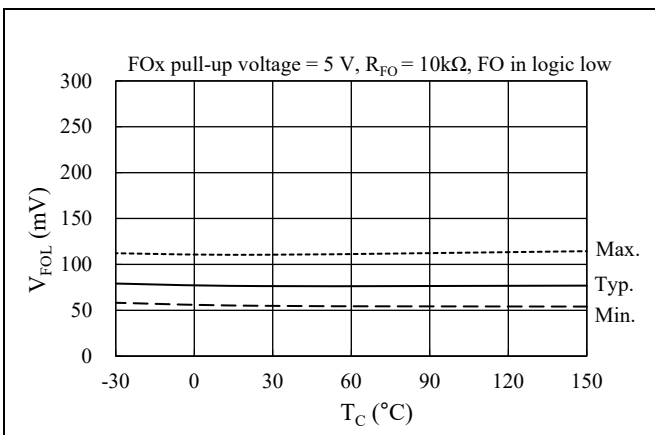

Figure 15-17. FO Pin Voltage in Normal Operation, V_{FOL} vs. T_C

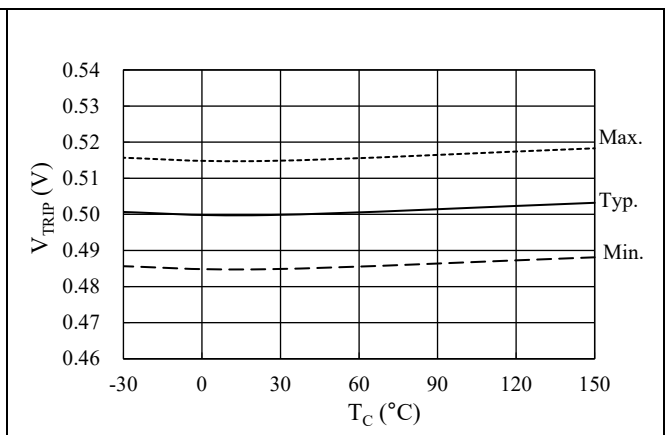

Figure 15-18. OCP Threshold Voltage, V_{TRIP} vs. T_C

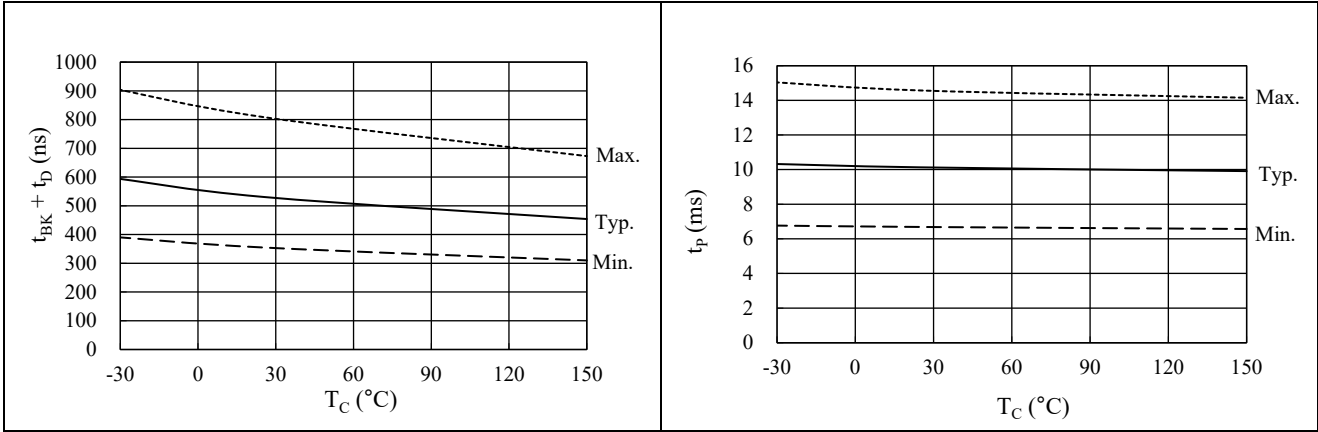

Figure 15-19. OCP Blanking Time, $t_{BK(OCP)} + t_{D(OCP)}$ vs. T_C

Figure 15-20. OCP Hold Time, t_p vs. T_C

15.2. Performance Curves of Output Parts

15.2.1. Output Transistor Performance Curves

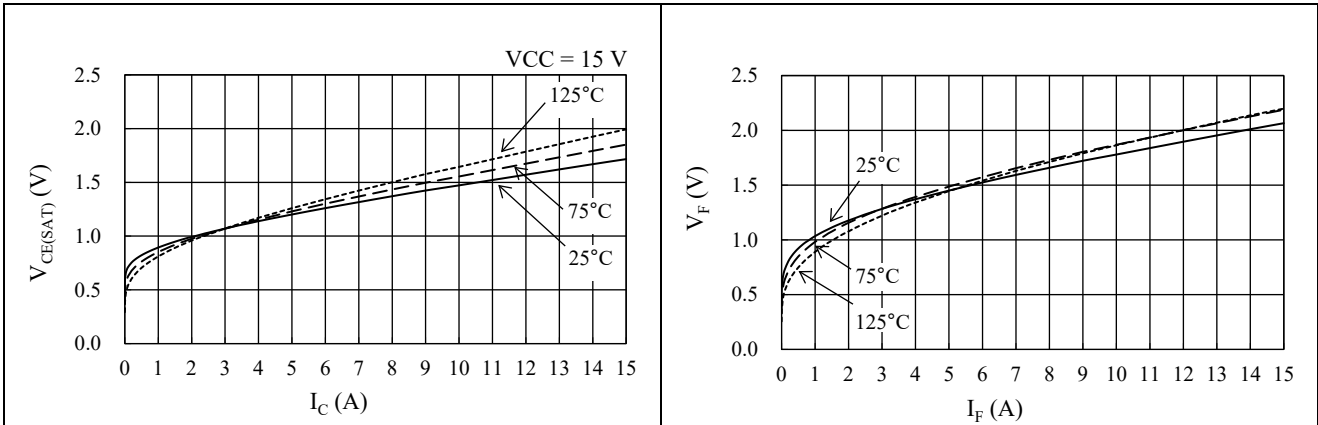

Figure 15-21. IGBT $V_{CE(SAT)}$ vs. I_C

Figure 15-22. Freewheeling Diode V_F vs. I_F

15.2.2. Switching Loss Curves

Conditions: VBB pin voltage = 300 V, half-bridge circuit with inductive load.
Switching Loss, E, is the sum of turn-on loss and turn-off loss.

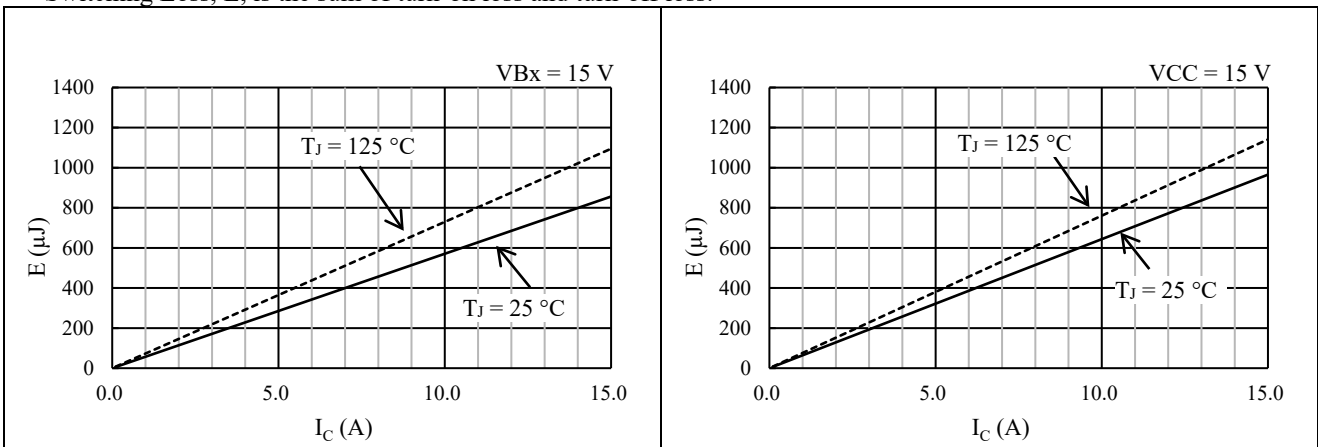

Figure 15-23. High-side Switching Loss

Figure 15-24. Low-side Switching Loss

15.3. Allowable Effective Current Curves

The following curves represent allowable effective currents in 3-phase sine-wave PWM driving with parameters such as typical $V_{CE(SAT)}$ and typical switching losses.

Operating conditions: VBB pin input voltage, $V_{DC} = 300\text{ V}$; VCC pin input voltage, $V_{CC} = 15\text{ V}$; modulation index, $M = 0.9$; motor power factor, $\cos\theta = 0.8$; junction temperature, $T_J = 150\text{ }^\circ\text{C}$.

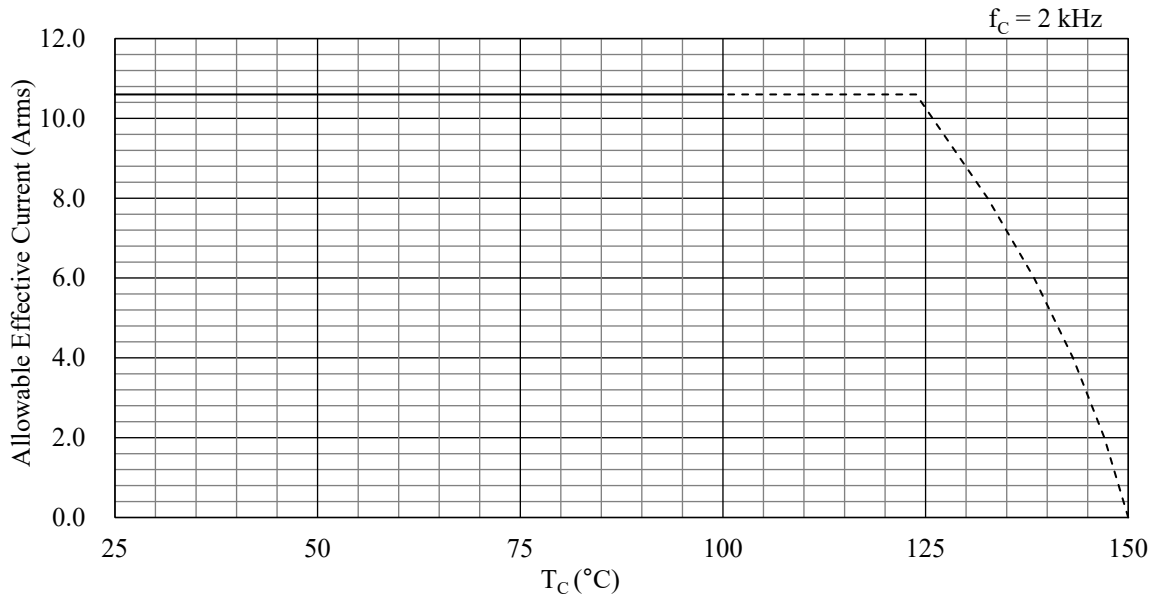

Figure 15-25. Allowable Effective Current ($f_C = 2\text{ kHz}$)

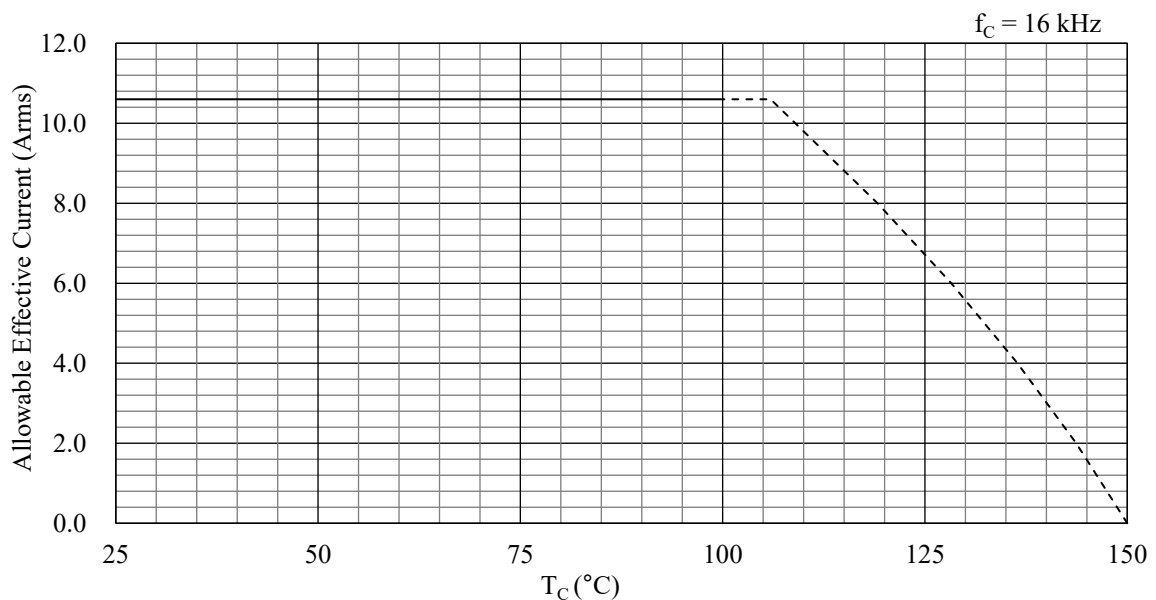

Figure 15-26. Allowable Effective Current ($f_C = 16\text{ kHz}$)

15.4. Transient Thermal Resistance Curve

The following graphs represent transient thermal resistance (the ratios of transient thermal resistance), with steady-state junction-to-case thermal resistance = 1. Note that the graph shows only IGBT characteristics; no freewheeling diode characteristics are included.

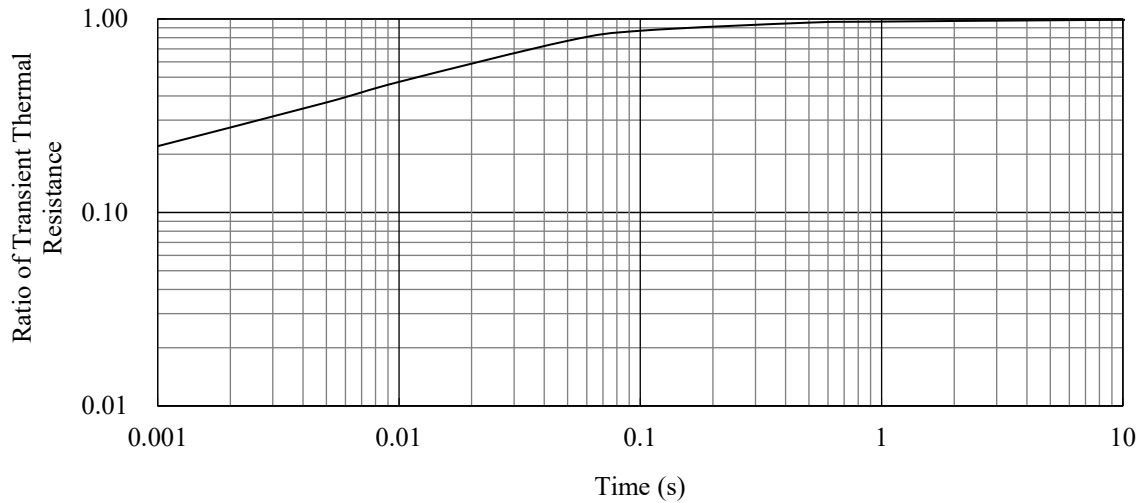

Figure 15-27. Transient Thermal Resistance

15.5. Short Circuit SOA (Safe Operating Area)

Conditions: $V_{DC} \leq 400$ V, 13.5 V \leq VCC \leq 16.5 V, $T_J = 125$ °C, 1 pulse.



Figure 15-28. Short Circuit SOA

16. Pattern Layout Example

This section contains the schematic diagrams of a PCB pattern layout example using an SIM2-151A series device. Note that the pattern layout example only uses the parts illustrated in the circuit diagram below. For more details on through holes, see Section 10.

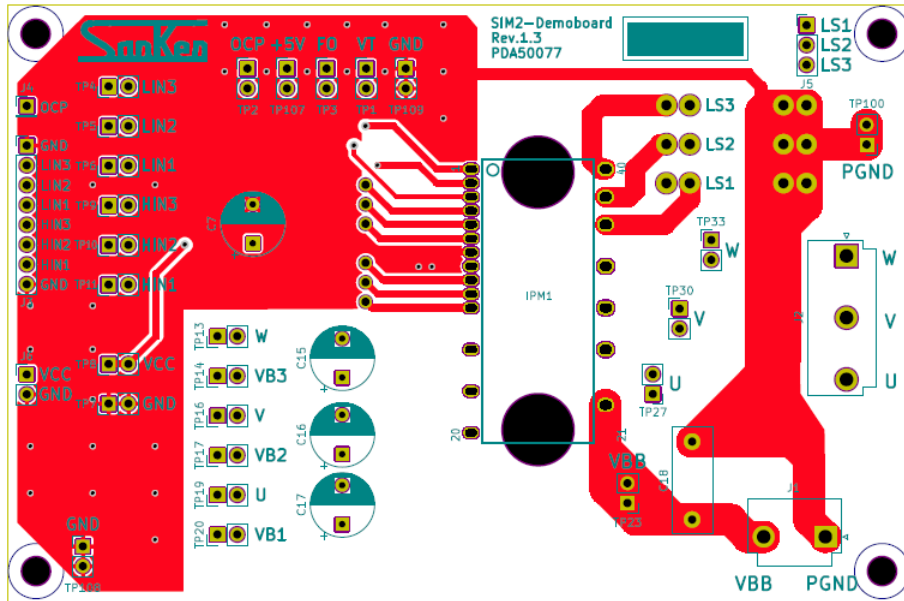

(Top View)

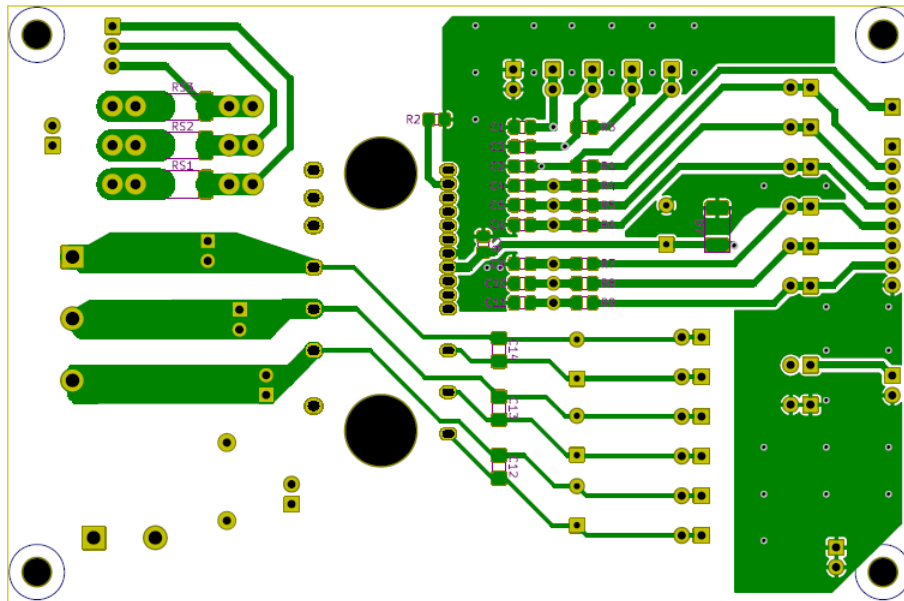

(Bottom View)

Figure 16-1. Pattern Layout Example

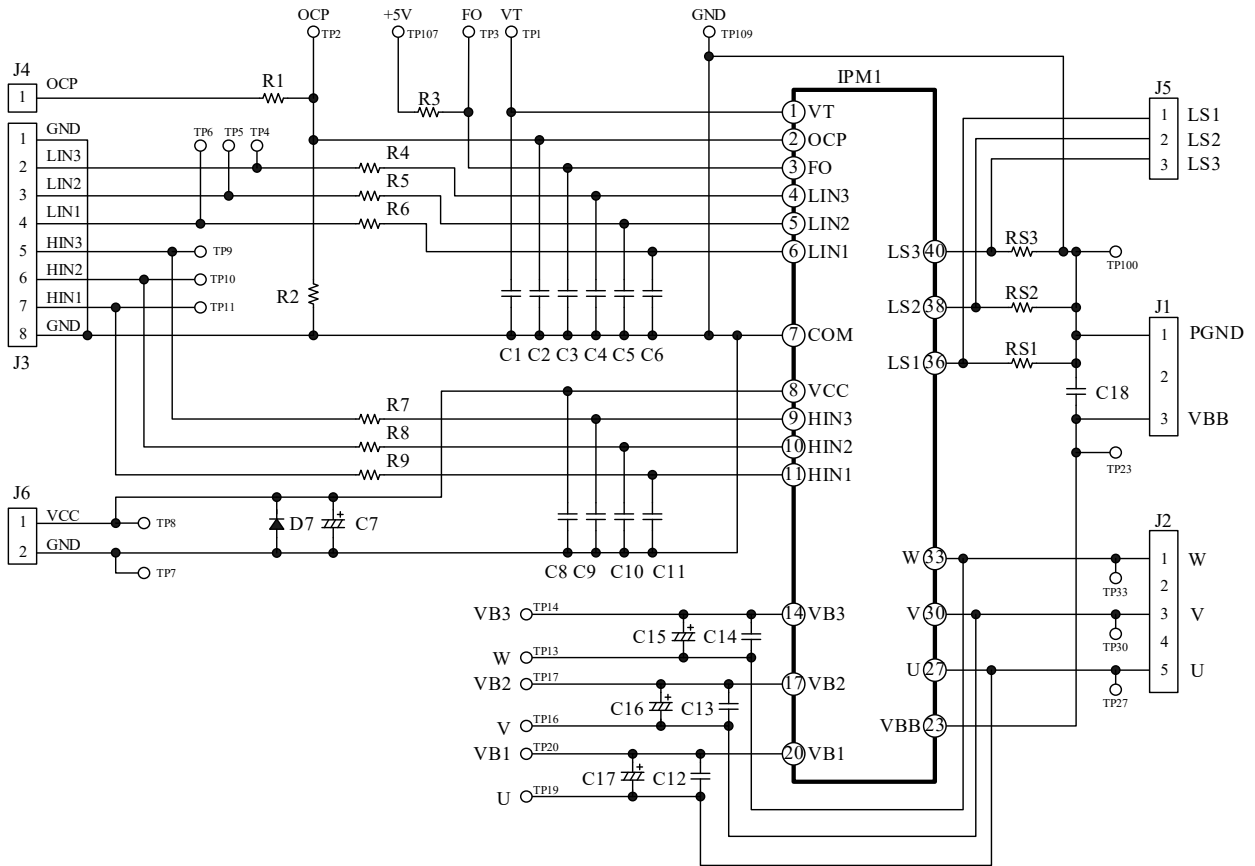

Figure 16-2. Circuit Diagram of PCB Pattern Layout Example

SIM2-151A

17. Typical Motor Driver Application

This section contains the information on the typical motor driver application listed in the previous section, including a circuit diagram, specifications, and the bill of the materials used.

• Motor Driver Specifications

IC	SIM2-151A
Main Supply Voltage, V _{DC}	300 VDC (typ.)
Rated Output Power	500 W

• Circuit Diagram

See Figure 16-2.

• Bill of Materials

Symbol	Part Type	Ratings
C1	Chip ceramic capacitor	0.01 μ F, 50 V
C2	Chip ceramic capacitor	10 nF, 50 V
C3	Chip ceramic capacitor	0.01 μ F, 50 V
C4	Chip ceramic capacitor	100 pF, 50 V
C5	Chip ceramic capacitor	100 pF, 50 V
C6	Chip ceramic capacitor	100 pF, 50 V
C7	Electrolytic capacitor	47 μ F, 25 V
C8	Chip ceramic capacitor	0.1 μ F, 50 V
C9	Chip ceramic capacitor	100 pF, 50 V
C10	Chip ceramic capacitor	100 pF, 50 V
C11	Chip ceramic capacitor	100 pF, 50 V
C12	Chip ceramic capacitor	0.1 μ F, 50 V
C13	Chip ceramic capacitor	0.1 μ F, 50 V
C14	Chip ceramic capacitor	0.1 μ F, 50 V
C15	Electrolytic capacitor	10 μ F, 50 V
C16	Electrolytic capacitor	10 μ F, 50 V
C17	Electrolytic capacitor	10 μ F, 50 V
C18	Film capacitor	0.1 μ F, 450 V
R1	Chip resistor	100 Ω , 1/8 W
R2	Chip resistor	Open
R3	Chip resistor	10 k Ω , 1/8 W
R4	Chip resistor	100 Ω , 1/8 W
R5	Chip resistor	100 Ω , 1/8 W
R6	Chip resistor	100 Ω , 1/8 W
R7	Chip resistor	100 Ω , 1/8 W
R8	Chip resistor	100 Ω , 1/8 W
R9	Chip resistor	100 Ω , 1/8 W
RS1*	Metal plate resistor	18 m Ω , 2 W
RS2*	Metal plate resistor	18 m Ω , 2 W
RS3*	Metal plate resistor	18 m Ω , 2 W
D7	Diode	Open
IPM1	Motor Diver IC	SIM2-151A
J1	Connector	Equiv. to B2P3-VH
J2	Connector	Equiv. to B3P5-VH
J3	Pin header	Equiv. to MA08-1
J4	Pin header	Equiv. to MA01-1
J5	Pin header	Equiv. to MA03-1
J6	Pin header	Equiv. to MA02-1

* Refers to a part that requires adjustment based on operation performance in an actual application.

Important Notes

- All data, illustrations, graphs, tables and any other information included in this document (the “Information”) as to Sanken’s products listed herein (the “Sanken Products”) are current as of the date this document is issued. The Information is subject to any change without notice due to improvement of the Sanken Products, etc. Please make sure to confirm with a Sanken sales representative that the contents set forth in this document reflect the latest revisions before use.
- The Sanken Products are intended for use as components of general purpose electronic equipment or apparatus (such as home appliances, office equipment, telecommunication equipment, measuring equipment, etc.). Prior to use of the Sanken Products, please put your signature, or affix your name and seal, on the specification documents of the Sanken Products and return them to Sanken. When considering use of the Sanken Products for any applications that require higher reliability (such as transportation equipment and its control systems, traffic signal control systems or equipment, disaster/crime alarm systems, various safety devices, etc.), you must contact a Sanken sales representative to discuss the suitability of such use and put your signature, or affix your name and seal, on the specification documents of the Sanken Products and return them to Sanken, prior to the use of the Sanken Products. The Sanken Products are not intended for use in any applications that require extremely high reliability such as: aerospace equipment; nuclear power control systems; and medical equipment or systems, whose failure or malfunction may result in death or serious injury to people, i.e., medical devices in Class III or a higher class as defined by relevant laws of Japan (collectively, the “Specific Applications”). Sanken assumes no liability or responsibility whatsoever for any and all damages and losses that may be suffered by you, users or any third party, resulting from the use of the Sanken Products in the Specific Applications or in manner not in compliance with the instructions set forth herein.
- In the event of using the Sanken Products by either (i) combining other products or materials or both therewith or (ii) physically, chemically or otherwise processing or treating or both the same, you must duly consider all possible risks that may result from all such uses in advance and proceed therewith at your own responsibility.
- Although Sanken is making efforts to enhance the quality and reliability of its products, it is impossible to completely avoid the occurrence of any failure or defect or both in semiconductor products at a certain rate. You must take, at your own responsibility, preventative measures including using a sufficient safety design and confirming safety of any equipment or systems in/for which the Sanken Products are used, upon due consideration of a failure occurrence rate and derating, etc., in order not to cause any human injury or death, fire accident or social harm which may result from any failure or malfunction of the Sanken Products. Please refer to the relevant specification documents and Sanken’s official website in relation to derating.
- No anti-radioactive ray design has been adopted for the Sanken Products.
- The circuit constant, operation examples, circuit examples, pattern layout examples, design examples, recommended examples, all information and evaluation results based thereon, etc., described in this document are presented for the sole purpose of reference of use of the Sanken Products.
- Sanken assumes no responsibility whatsoever for any and all damages and losses that may be suffered by you, users or any third party, or any possible infringement of any and all property rights including intellectual property rights and any other rights of you, users or any third party, resulting from the Information.
- No information in this document can be transcribed or copied or both without Sanken’s prior written consent.
- Regarding the Information, no license, express, implied or otherwise, is granted hereby under any intellectual property rights and any other rights of Sanken.
- Unless otherwise agreed in writing between Sanken and you, Sanken makes no warranty of any kind, whether express or implied, including, without limitation, any warranty (i) as to the quality or performance of the Sanken Products (such as implied warranty of merchantability, and implied warranty of fitness for a particular purpose or special environment), (ii) that any Sanken Product is delivered free of claims of third parties by way of infringement or the like, (iii) that may arise from course of performance, course of dealing or usage of trade, and (iv) as to the Information (including its accuracy, usefulness, and reliability).
- In the event of using the Sanken Products, you must use the same after carefully examining all applicable environmental laws and regulations that regulate the inclusion or use or both of any particular controlled substances, including, but not limited to, the EU RoHS Directive, so as to be in strict compliance with such applicable laws and regulations.
- You must not use the Sanken Products or the Information for the purpose of any military applications or use, including but not limited to the development of weapons of mass destruction. In the event of exporting the Sanken Products or the Information, or providing them for non-residents, you must comply with all applicable export control laws and regulations in each country including the U.S. Export Administration Regulations (EAR) and the Foreign Exchange and Foreign Trade Act of Japan, and follow the procedures required by such applicable laws and regulations.
- Sanken assumes no responsibility for any troubles, which may occur during the transportation of the Sanken Products including the falling thereof, out of Sanken’s distribution network.
- Although Sanken has prepared this document with its due care to pursue the accuracy thereof, Sanken does not warrant that it is error free and Sanken assumes no liability whatsoever for any and all damages and losses which may be suffered by you resulting from any possible errors or omissions in connection with the Information.
- Please refer to our official website in relation to general instructions and directions for using the Sanken Products, and refer to the relevant specification documents in relation to particular precautions when using the Sanken Products.
- All rights and title in and to any specific trademark or tradename belong to Sanken and such original right holder(s).